

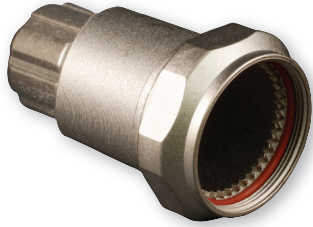

712-419
Lightweight Composite Hummer-Nut System
Composite Backshell for Series 74 Helical Convoluted Tubing,
Shielding Optional

Lightweight Composite Hummer Nut conduit-to-connector backshell



How To Order

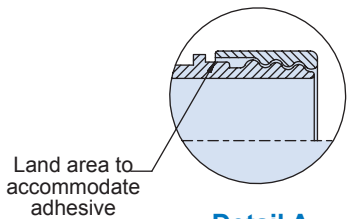
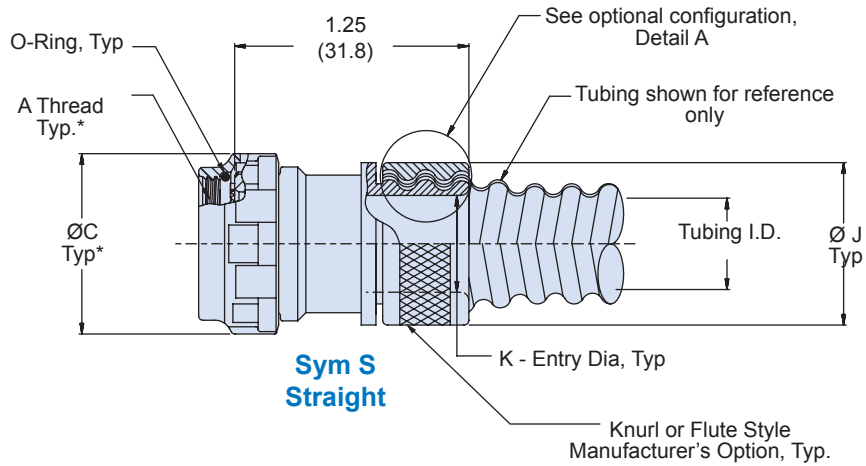
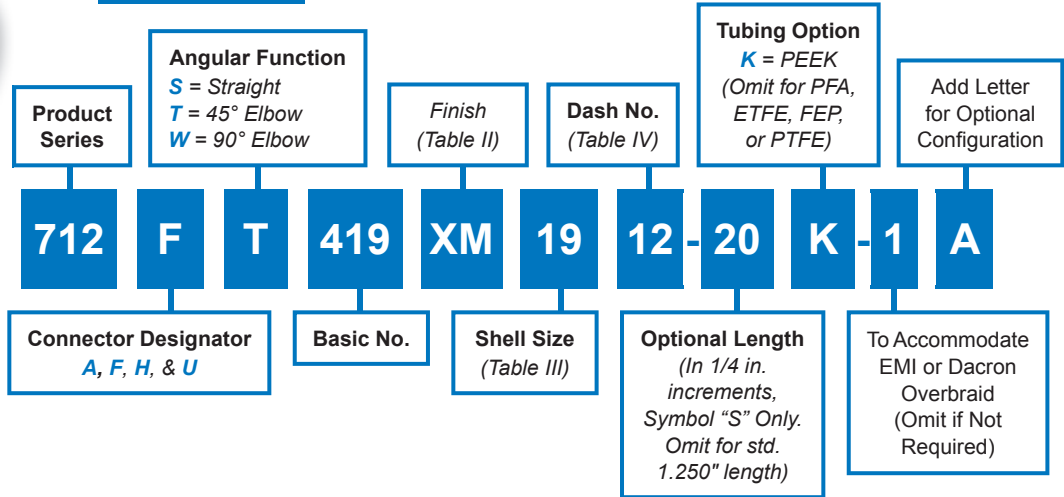

Detail A
Optional adhesive land configuration, see P/N

Material/Finish

- Adapters, elbows, ferrules, coupling nuts: High grade engineering thermoplastic/ See Table II
- O-Ring: Silicone/NA

Assembly Notes

- Nominal I.D. of PEEK tubing adapters are reduced by approximately .060 in.
- For permanent installation use 3M Scotch Weld Tape after installing tubing/shield.
- O-Ring not supplied with connector designator A
- * See composite catalog for front end dimensions

712-419
Lightweight Composite Hammer-Nut System
Composite Backshell for Series 74 Helical Convuluted Tubing,
Shielding Optional



Shell Size		E	F	G	H	Tubing Size
A, F, & H	G & U	± .06 (1.5)	± .09 (2.3)	± .06 (1.5)	± .09 (2.3)	Max.
08, 09	-	.72 (18.3)	.89 (22.6)	.69 (17.5)	1.11 (28.2)	09
3, 10, 11	08	.75 (19.1)	.95 (24.1)	.75 (19.1)	1.16 (29.5)	12
12, 13	10, 11	.75 (19.1)	1.02 (25.9)	.81 (20.6)	1.22 (31.0)	16
14, 15	12, 13	.76 (19.3)	1.05 (26.7)	.88 (22.4)	1.29 (32.8)	20
16, 17	14, 15	.78 (19.8)	1.07 (27.2)	.94 (23.9)	1.35 (34.3)	24
18, 19	16, 17	.79 (20.1)	1.08 (27.4)	.97 (24.6)	1.38 (35.1)	28
20, 21	18, 19	.82 (20.8)	1.11 (28.2)	1.06 (26.9)	1.47 (37.3)	32
22, 23	20	.86 (21.8)	1.15 (29.2)	1.13 (28.7)	1.54 (39.1)	32
24, 25, 61	22, 23	.89 (22.6)	1.18 (30.0)	1.19 (30.2)	1.73 (43.9)	40
28	24, 25	.92 (23.4)	1.21 (30.7)	1.34 (34.0)	1.82 (46.2)	40

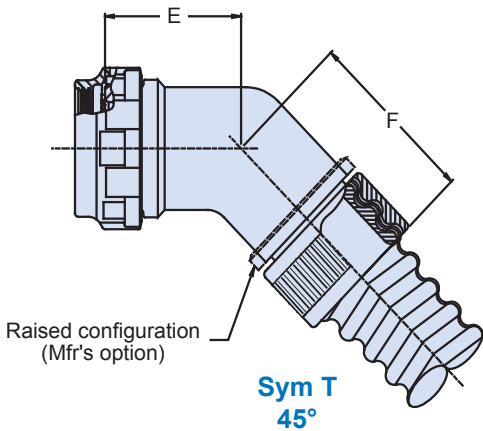

Dash No.	Conduit I.D.	Ø J Max	Ø K Entry
06	.188 (4.8)	.54 (13.7)	.12 (3.0)
09	.281 (7.1)	.63 (16.0)	.22 (5.6)
10	.312 (7.9)	.69 (17.5)	.24 (6.1)
12	.375 (9.5)	.73 (18.5)	.29 (7.4)
14	.437 (11.1)	.80 (20.3)	.34 (8.6)
16	.500 (12.7)	.87 (22.1)	.40 (10.2)
20	.625 (15.9)	1.00 (25.4)	.52 (13.2)
24	.750 (19.1)	1.18 (30.0)	.65 (16.5)
28	.875 (22.2)	1.32 (33.5)	.78 (19.8)
32	1.000 (25.4)	1.47 (37.3)	.90 (22.9)
40	1.250 (31.8)	1.76 (53.3)	1.08 (27.4)
48	1.500 (38.1)	2.13 (54.1)	1.32 (33.5)

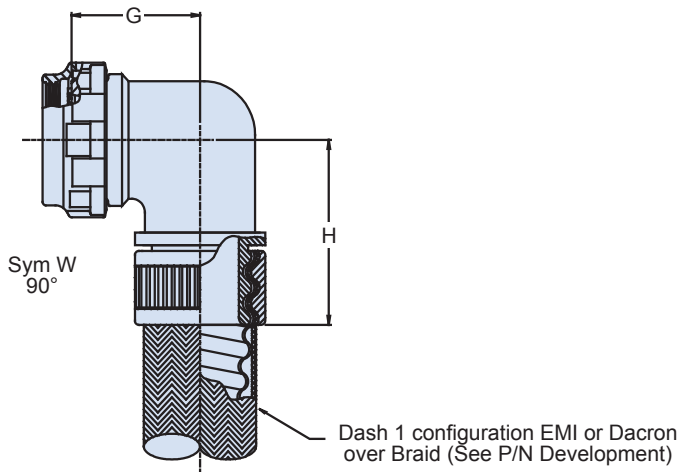

Sym	Finish
XM	Electroless Nickel
XW	Cadmium Olive Drab over Electroless Nickel
XB	No Plating - Black Material
XO	No Plating - Natural, Non-conductive