

How To Order: Commercial

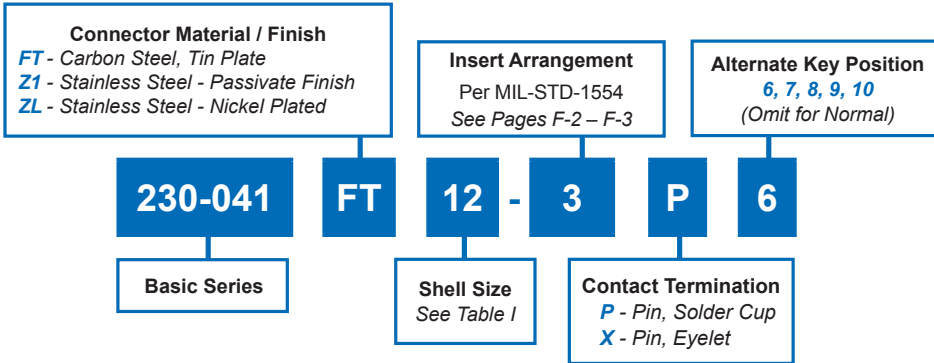

F

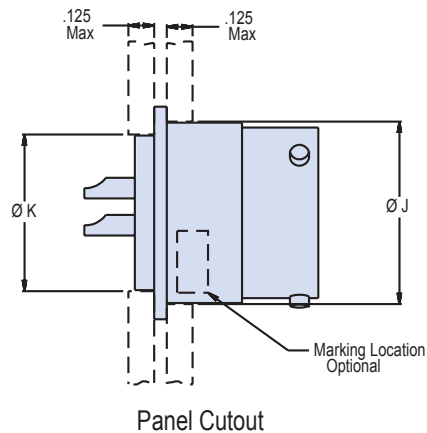
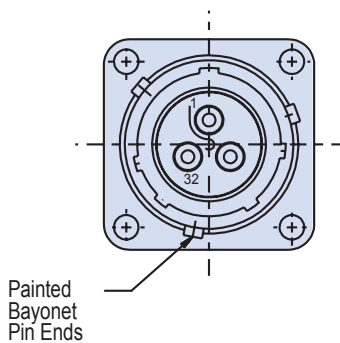
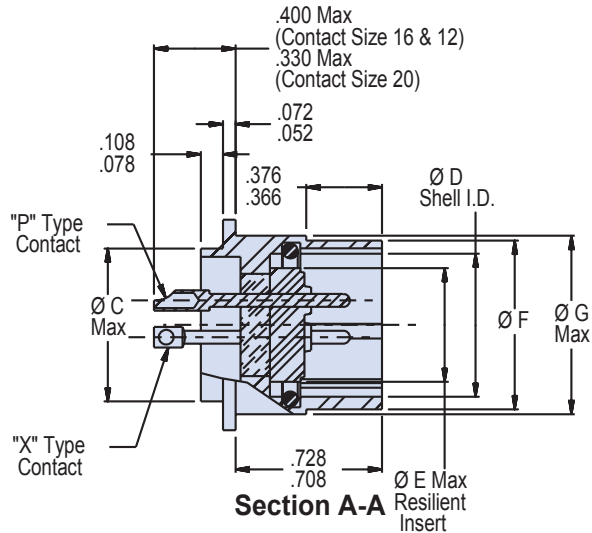
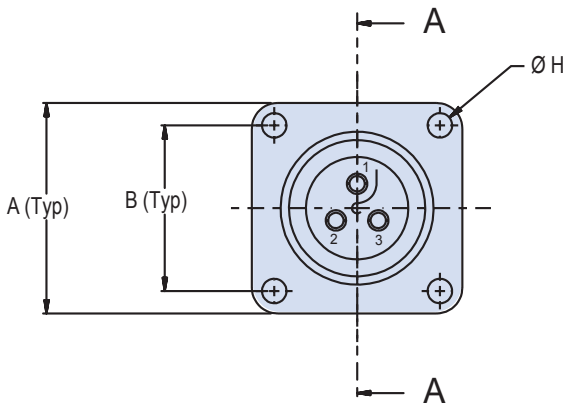

Dimensions in Inches (millimeters) are subject to change without notice.

230-041
MIL-DTL-26500 Type Hermetic Class Receptacle
Square Flange Mount, Bayonet Coupling, MS24264B*** Type**



MIL-DTL-26500
Type

F

TABLE I: Shell Size, Connector Dimensions and Panel Cut-Out

Shell Size	A	B	CØ Max	DØ Shell I.D.	EØ Resilient Insert	FØ	GØ Max	HØ Thru 4 Pl.	Panel Cutout Rear Mount JØ	Panel Cutout Front Mount K Ø
8	0.812 (20.6)	0.594 (15.1)	0.437 (11.1)	.433/.428 (11.0/10.9)	0.312 (7.9)	.536/.531 (13.6/13.5)	0.561 (14.2)	0.120 (3.0)	.630/.620 (16.0/15.7)	.457/.447 (11.6/11.4)
10	0.937 (23.8)	0.719 (18.3)	0.562 (14.3)	.535/.530 (13.6/13.5)	0.388 (9.9)	.659/.654 (16.7/16.6)	0.696 (17.7)	0.120 (3.0)	.758/.748 (19.3/19.0)	.582/.572 (14.8/14.5)
12	1.031 (26.2)	0.812 (20.6)	0.750 (19.1)	.705/.700 (17.9/17.8)	0.558 (14.2)	.829/.824 (21.1/20.9)	0.875 (22.2)	0.120 (3.0)	.923/.913 (23.4/23.2)	.770/.760 (19.6/19.3)
14	1.125 (28.6)	0.906 (23.0)	0.812 (20.6)	.774/.769 (19.7/19.5)	0.627 (15.9)	.898/.893 (22.8/22.7)	0.935 (23.7)	0.120 (3.0)	.990/.980 (25.1/24.9)	.832/.822 (21.1/20.9)
16	1.250 (31.8)	0.969 (24.6)	0.937 (23.8)	.901/.896 (22.9/22.8)	0.772 (19.6)	1.025/1.020 (26.0/25.9)	1.062 (27.0)	0.120 (3.0)	1.117/1.107 (28.4/28.1)	.958/.948 (24.3/24.1)
18	1.343 (34.1)	1.062 (27.0)	1.062 (27.0)	1.007/1.002 (25.6/25.5)	0.860 (21.8)	1.131/1.126 (28.7/28.6)	1.187 (30.1)	0.120 (3.0)	1.219/1.209 (31.0/30.7)	1.082/1.072 (27.5/27.2)
20	1.437 (36.5)	1.156 (29.4)	1.187 (30.1)	1.132/1.125 (28.8/28.6)	0.985 (25.0)	1.256/1.251 (31.9/31.8)	1.312 (33.3)	0.120 (3.0)	1.347/1.337 (34.2/34.0)	1.202/1.192 (30.5/30.3)
22	1.562 (39.7)	1.250 (31.8)	1.312 (33.3)	1.257/1.252 (31.9/31.8)	1.110 (28.2)	1.381/1.376 (35.1/35.0)	1.437 (36.5)	0.120 (3.0)	1.462/1.452 (37.1/36.9)	1.332/1.322 (33.8/33.6)
24	1.703 (43.3)	1.375 (34.9)	1.437 (36.5)	1.382/1.377 (35.1/35.0)	1.235 (31.4)	1.506/1.501 (38.3/38.1)	1.562 (39.7)	0.149 (3.8)	1.587/1.577 (40.3/40.1)	1.452/1.442 (36.9/36.6)

APPLICATION NOTES

- Assembly identified with manufacturer's name and part number, space permitting.
- Glenair 230-041 will mate with any QPL MIL-DTL-MS24266 type bayonet coupling plug of same size, keyway and insert polarization.
- Performance:
 Hermeticity - $< \times 10^{-7}$ ccHe/sec @ 1 atmosphere differential
 Dielectric withstanding voltage - consult factory or MIL-STD-1554
 Insulation resistance - 5000 megohms min @ 500VDC
- Material/ Finish:
 Shell—specified by class
 Bayonets—Stainless Steel/Passivated
 Contacts—52 Nickel alloy/Gold plated
 Insulators—Glass/NA
 Seals—fluorosilicone elastomer N.A.
- Metric Dimensions (mm) are indicated in parentheses.

Dimensions in Inches (millimeters) are subject to change without notice.