

1770-5012 Code Red Lightweight Hermetic Connectors

Solder cup or PC tail options

Front Weld Mount



Micro-D
Hermetic

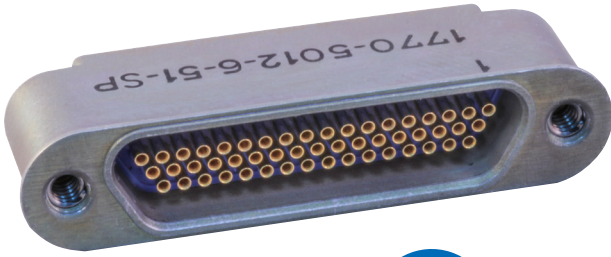

MATES WITH ALL 83513 Pin Connectors



Code Red Encapsulant proprietary Glenair encapsulant and application process provides a lightweight alternative to heavy Kovar shells typically used in glass to metal hermetic connectors while using standard gold-plated copper alloy contacts. Connectors are rated to -65° C to +175° C. Hermeticity of 1×10^{-7} sccHe/sec @ 1 atmosphere.

Solder Cup or PC Tail type contacts Suitable for #26 gage wire or smaller, solder cup versions feature copper alloy/gold-plated contacts. Choose PC tails for attachment to flex circuits or rigid boards. Solder cup versions available pre-wired. Both contact options are non-removable and back potted. Mates with M83513/1 style plug connectors with same shell size/arrangement and opposite contact gender. Connector is designed to be laser welded into an electronic chassis wall.

How To Order Code Red Light Weight Hermetic Micro-D Connectors with Solder Cups or PC Tails					
Sample Part Number		1770-5012	-6	-25	-SC
Series	1770-5012 Code Red Hermetic Micro-D				
Material/Finish	3 - 304L Stainless Steel, Passivated 6 - Aluminum Alloy, MIL-DTL-5541, Typ I, CL 3				
Insert Arrangement	Pin Counts: 9, 15, 21, 25, 31, 37, and 51 Per MIL-PRF-83513; See page 4 for contact layouts				
Contact Type	SP – socket engagement with PC tail termination SC – socket engagement with solder cup termination				

Number of Contacts	A	B	C Basic
9	.277 (7.04)	.795 (20.19)	.565 (14.35)
15	.277 (7.04)	.945 (24.00)	.715 (18.16)
21	.277 (7.04)	1.095 (27.81)	.865 (21.97)
25	.277 (7.04)	1.195 (30.35)	.965 (24.51)
31	.277 (7.04)	1.345 (34.16)	1.115 (28.32)
37	.277 (7.04)	1.495 (37.97)	1.265 (32.13)
51	.320 (8.13)	1.445 (36.70)	1.215 (30.86)

Material/finish

- Housing: see part number development
- Contacts: copper alloy/gold plate
- Threaded inserts: stainless steel/passivated
- Insulator: high grade rigid dielectric/N.A.
- Interfacial seal: fluorosilicone/N.A.
- Sealing compound: polymer encapsulant

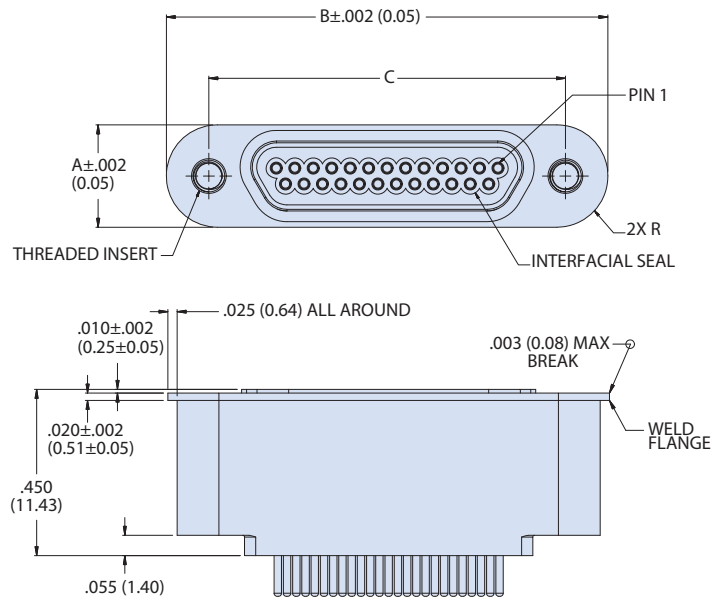

H



1770-5012 Code Red Lightweight Hermetic Connectors

Solder cup or PC tail options

Front Weld Mount

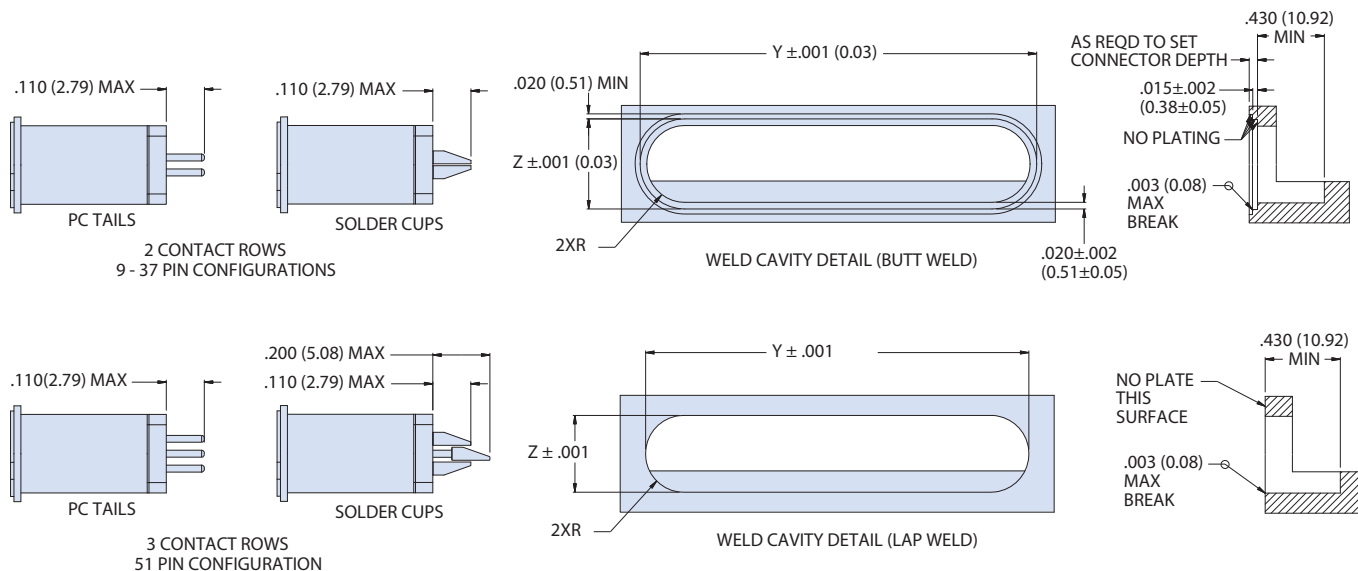

Cutout Dimensions

Number of Contacts	Lap Weld		Butt Weld	
	Y	Z	Y	Z
9	.748 (19.00)	.230 (5.84)	.798 (20.27)	.280 (7.11)
15	.898 (22.81)	.230 (5.84)	.948 (24.08)	.280 (7.11)
21	1.048 (26.62)	.230 (5.84)	1.098 (27.89)	.280 (7.11)
25	1.148 (29.16)	.230 (5.84)	1.198 (30.43)	.280 (7.11)
31	1.298 (32.97)	.230 (5.84)	1.348 (34.24)	.280 (7.11)
37	1.448 (36.78)	.230 (5.84)	1.498 (38.05)	.280 (7.11)
51	1.398 (35.51)	.273 (6.93)	1.448 (36.78)	.323 (8.20)