

240-288W Filtered Wall Mount Receptacle MIL-DTL-28840 Type

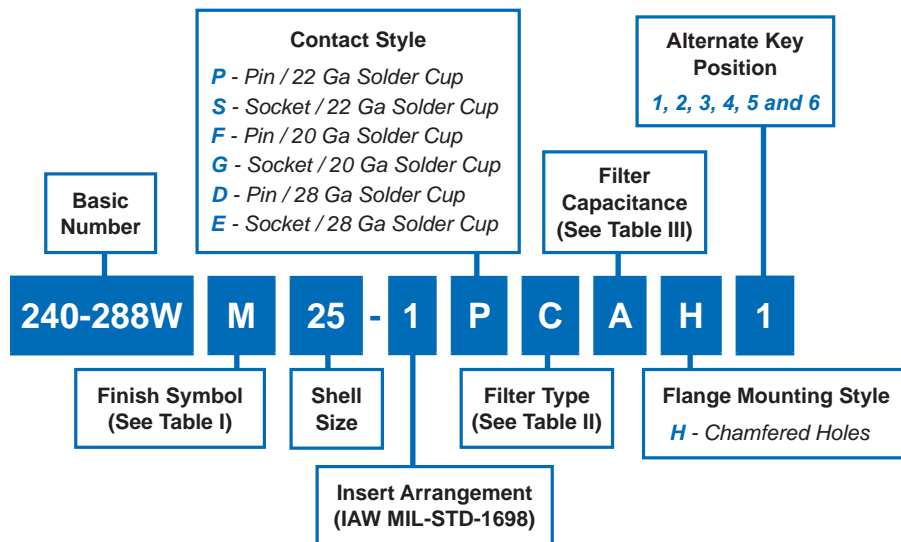

MIL-DTL
28840



B

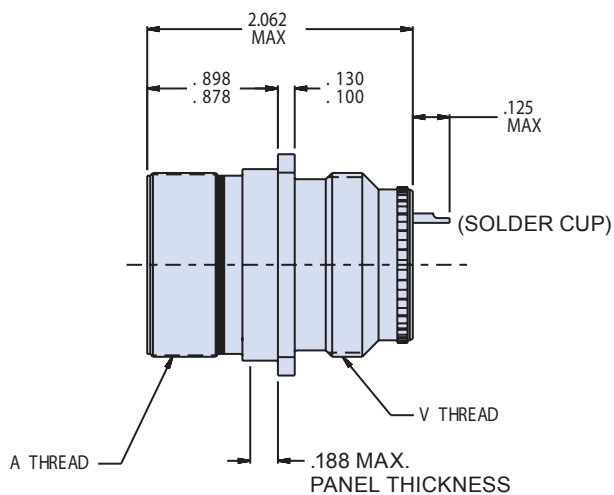
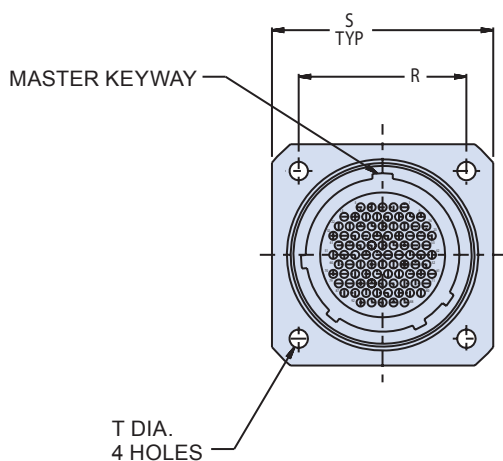

Symbol	Material	Finish Description
M	Aluminum	Electroless Nickel
MT	Aluminum	Nickel-PTFE, 1000 Hour Grey™
NF	Aluminum	Cadmium O.D. over Electroless Nickel
P	Stainless Steel	Electrodeposited Nickel

Class	PI-Section (pF)	C-Section (pF)
X	160,000 - 240,000	80,000 - 120,000
Y	80,000 - 120,000	40,000 - 60,000
Z	60,000 - 91,000	30,000 - 45,000
A	38,000 - 56,000	19,000 - 28,000
B	32,000 - 45,000	16,000 - 22,500
C	18,000 - 33,000	9,000 - 16,500
D	8,000 - 12,000	4,000 - 6,000
E	3,300 - 5,000	1,650 - 2,500
F	800 - 1,300	400 - 650
G	400 - 600	200 - 300

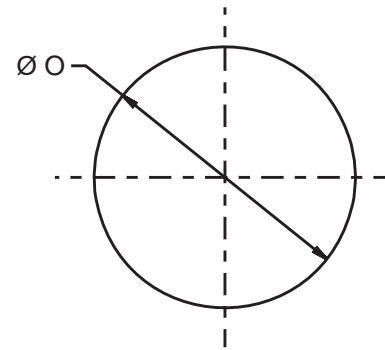

RECOMMENDED PANEL CUT OUT

Filter Type	
P	PI-Section
C	C-Section

Military Shell Size	Shell Size	A Thread Class 2A	V Thread Class 2A	O Ref. Mtg. Hole	R True Position \varnothing to \varnothing	S	T Diameter
A	11	.750-.1P-.2L-D.S.	.750-20 UNEF	.812	.750	1.043 1.003	.130 .115
B	13	.875-.1P-.2L-D.S.	.875-20 UNEF	.937	.843	1.158 1.118	
C	15	1.062-.1P-.2L-D.S.	1.000-20 UNEF	1.124	.968	1.278 1.238	
D	17	1.125-.1P-.2L-D.S.	1.125-18 UNEF	1.187	1.015	1.403 1.363	
E	19	1.312-.1P-.2L-D.S.	1.250-18 UNEF	1.374	1.140	1.528 1.488	
F	23	1.500-.1P-.2L-D.S.	1.437-18 UNEF	1.562	1.281	1.738 1.698	
G	25	1.625-.1P-.2L-D.S.	1.562-18 UNEF	1.687	1.392	1.838 1.798	.157 .142
H	29	1.812-.1P-.2L-D.S.	1.875-16 UN	1.874	1.568	2.158 2.118	
J	33	2.000-.1P-.2L-D.S.	2.062-16 UNS	2.062	1.734	2.348 2.308	.183 .168