

For Strain Relief Styles H, A, M and D

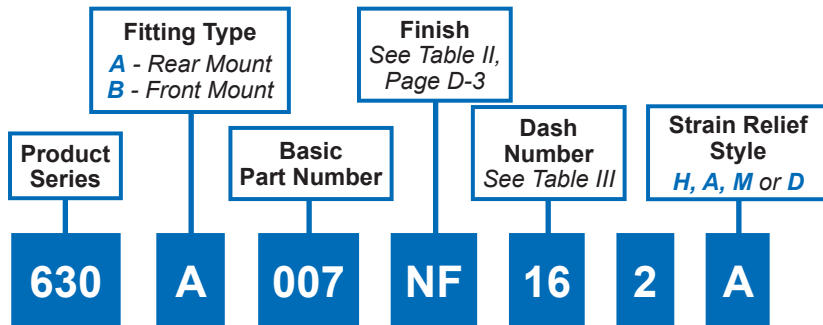

- APPLICATION NOTES**
1. Assembly identified with manufacturer's name and part number, space permitting.
 2. Cable range is defined as the accommodations range for the wire bundle or cable. Dimensions shown are not intended for inspection criteria.
 3. Material / Finish: See Table II.
 4. Metric dimensions (mm) are indicated in parentheses.
 5. Not available with Style "M" Clamp
 6. Not available with Style "H" Clamp

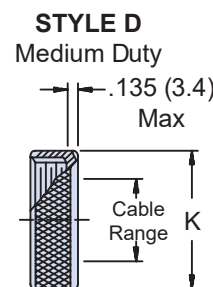
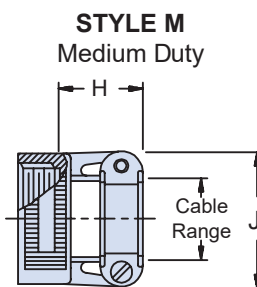
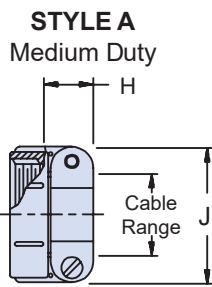
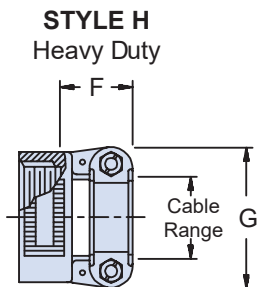
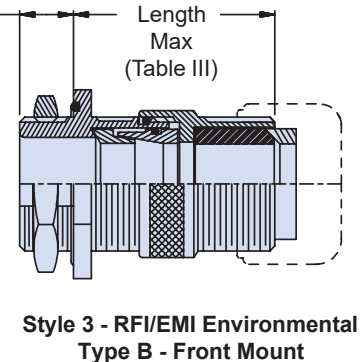
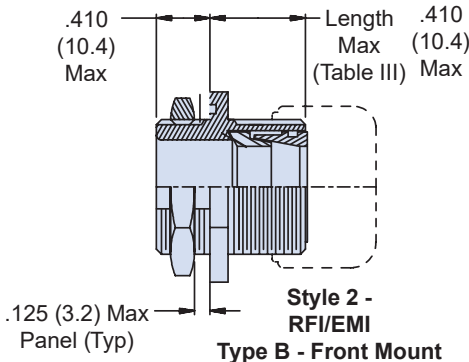
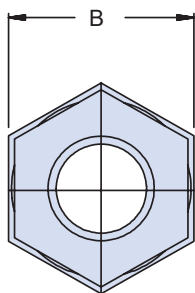
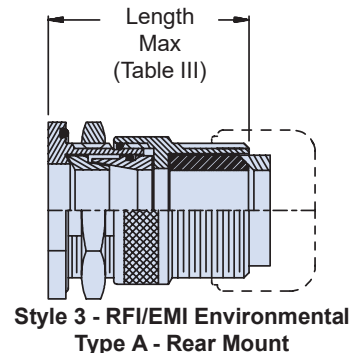
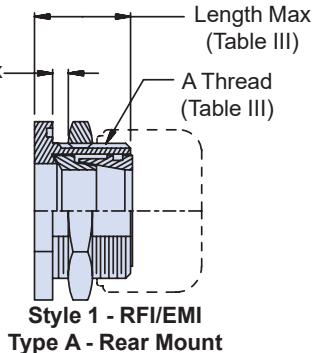
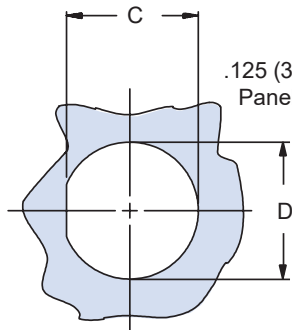

630-007
Jam Nut Feed-Through Fittings
RFI/EMI Environmental



Feed-Throughs

TABLE III: Dash Number, Cable Range and Dimensions (Continued Below)

Dash No.	Style	Clamp Size	Cable Range		A Thread Unified	B Dim	C Flat		D Dia	
			Min	Max			± .010	(± .3)	± .010	(± .3)
01	1, 2, 4	03 ^{5,6}	.157 (4.0)	.250 (6.4)	1/2 -28	.688 (17.5)	.479 (12.2)	.515 (13.1)		
02	3	03 ^{5,6}	.157 (4.0)	.250 (6.4)	1/2 -28	.688 (17.5)	.479 (12.2)	.515 (13.1)		
03	1, 2, 4	04 ⁵	.187 (4.7)	.312 (7.9)	5/8 -24	.813 (20.7)	.595 (15.1)	.640 (16.3)		
04	3	04 ⁵	.187 (4.7)	.312 (7.9)	5/8 -24	.813 (20.7)	.595 (15.1)	.640 (16.3)		
05	1, 2, 4	06 ⁵	.281 (7.1)	.437 (11.1)	3/4 -20	.938 (23.8)	.720 (18.3)	.765 (19.4)		
06	3	06 ⁵	.281 (7.1)	.437 (11.1)	3/4 -20	.938 (23.8)	.720 (18.3)	.765 (19.4)		
07	1, 2, 4	08	.344 (8.7)	.562 (14.3)	7/8 -20	1.063 (27.0)	.845 (21.5)	.890 (22.6)		
08	3	08	.344 (8.7)	.562 (14.3)	7/8 -20	1.063 (27.0)	.845 (21.5)	.890 (22.6)		
09	1, 2, 4	10	.375 (9.5)	.625 (15.9)	1 -20	1.250 (31.8)	.970 (24.6)	1.015 (25.8)		
10	3	10	.375 (9.5)	.625 (15.9)	1 -20	1.250 (31.8)	.970 (24.6)	1.015 (25.8)		
11	1, 2, 4	12	.438 (11.1)	.750 (19.1)	1 3/16 -18	1.375 (34.9)	1.158 (29.4)	1.202 (30.5)		
12	3	12	.438 (11.1)	.750 (19.1)	1 3/16 -18	1.375 (34.9)	1.158 (29.4)	1.202 (30.5)		
13	1, 2, 4	16	.625 (15.9)	.937 (23.8)	1 7/16 -18	1.625 (41.3)	1.408 (35.8)	1.452 (36.9)		
14	3	16	.625 (15.9)	.937 (23.8)	1 7/16 -18	1.625 (41.3)	1.408 (35.8)	1.452 (36.9)		
15	1, 2, 4	20	.875 (22.2)	1.250 (31.8)	1 3/4 -18	2.000 (50.8)	1.720 (43.7)	1.765 (44.8)		
16	3	20	.875 (22.2)	1.250 (31.8)	1 3/4 -18	2.000 (50.8)	1.720 (43.7)	1.765 (44.8)		
17	1, 2, 4	24	1.000 (25.4)	1.375 (34.9)	2 -18	2.188 (55.6)	1.970 (50.0)	2.015 (51.2)		
18	3	24	1.000 (25.4)	1.375 (34.9)	2 -18	2.188 (55.6)	1.970 (50.0)	2.015 (51.2)		
19	1, 2, 4	28	1.250 (31.8)	1.625 (41.3)	2 1/4 -16	2.438 (61.9)	2.220 (56.4)	2.265 (57.5)		
20	3	28	1.250 (31.8)	1.625 (41.3)	2 1/4 -16	2.438 (61.9)	2.220 (56.4)	2.265 (57.5)		
21	1, 2, 4	32 ⁵	1.437 (36.5)	1.875 (47.6)	2 1/2 -16	2.813 (71.5)	2.470 (62.7)	2.515 (63.9)		
22	3	32 ⁵	1.437 (36.5)	1.875 (47.6)	2 1/2 -16	2.813 (71.5)	2.470 (62.7)	2.515 (63.9)		
23	1, 2, 4	40 ⁵	1.875 (47.6)	2.375 (60.3)	3 -16	3.375 (85.7)	2.970 (75.4)	3.015 (76.6)		
24	3	40 ⁵	1.875 (47.6)	2.375 (60.3)	3 -16	3.375 (85.7)	2.970 (75.4)	3.015 (76.6)		

TABLE III: (Continued from Above)

Dash No.	Style	E Max		F Max		G Max		H Max		J Max		Length Max
01	1, 2	---	---	---	---	.760 (19.3)	.843 (21.4)	.630 (16.0)	1.281 (32.5)			
02	3	---	---	---	---	.760 (19.3)	.843 (21.4)	.630 (16.0)	1.969 (50.0)			
03	1,2	.780 (19.8)	.957 (24.3)	.760 (19.3)	.906 (23.0)	.750 (19.2)	1.281 (32.5)					
04	3	.780 (19.8)	.957 (24.3)	.760 (19.3)	.906 (23.0)	.750 (19.2)	1.969 (50.0)					
05	1, 2	.780 (19.8)	1.145 (29.1)	.760 (19.3)	1.093 (27.8)	.942 (23.9)	1.281 (32.5)					
06	3	.780 (19.8)	1.145 (29.1)	.760 (19.3)	1.093 (27.8)	.942 (23.9)	1.969 (50.0)					
07	1,2	.780 (19.8)	1.332 (33.8)	.760 (19.3)	1.187 (30.1)	1.067 (27.1)	1.281 (32.5)					
08	3	.780 (19.8)	1.332 (33.8)	.760 (19.3)	1.187 (30.1)	1.067 (27.1)	1.969 (50.0)					
09	1, 2	.780 (19.8)	1.332 (33.8)	.760 (19.3)	1.281 (32.5)	1.192 (30.3)	1.281 (32.5)					
10	3	.780 (19.8)	1.332 (33.8)	.760 (19.3)	1.281 (32.5)	1.192 (30.3)	2.250 57.2					
11	1,2	.811 (20.6)	1.551 (39.4)	.760 (19.3)	1.500 (38.1)	1.380 (35.1)	1.344 (34.1)					
12	3	.811 (20.6)	1.551 (39.4)	.760 (19.3)	1.500 (38.1)	1.380 (35.1)	2.250 57.2					
13	1, 2	.905 (23.0)	1.770 (45.0)	1.073 (27.3)	1.719 (43.7)	1.535 (39.0)	1.344 (34.1)					
14	3	.905 (23.0)	1.770 (45.0)	1.073 (27.3)	1.719 (43.7)	1.535 (39.0)	2.250 57.2					
15	1,2	1.092 (27.7)	2.113 (53.7)	1.323 (33.6)	2.062 (52.4)	1.848 (46.9)	1.344 (34.1)					
16	3	1.092 (27.7)	2.113 (53.7)	1.323 (33.6)	2.062 (52.4)	1.848 (46.9)	2.250 57.2					
17	1, 2	1.124 (28.5)	2.363 (60.0)	1.323 (33.6)	2.312 (58.7)	2.255 (57.3)	1.406 (35.7)					
18	3	1.124 (28.5)	2.363 (60.0)	1.323 (33.6)	2.312 (58.7)	2.255 (57.3)	2.250 57.2					
19	1,2	1.399 (35.5)	2.770 (70.4)	1.572 (39.9)	2.719 (69.1)	2.505 (63.6)	1.406 (35.7)					
20	3	1.399 (35.5)	2.770 (70.4)	1.572 (39.9)	2.719 (69.1)	2.505 (63.6)	2.320 (58.9)					
21	1, 2	1.399 (35.5)	3.020 (76.7)	1.572 (39.9)	2.969 (75.4)	2.755 (70.0)	1.406 (35.7)					
22	3	1.399 (35.5)	3.020 (76.7)	1.572 (39.9)	2.969 (75.4)	2.755 (70.0)	2.375 (60.3)					
23	1,2	---	---	---	1.572 (39.9)	3.531 (89.7)	3.255 (82.7)	1.531 (38.9)				
24	3	---	---	---	1.572 (39.9)	3.531 (89.7)	3.255 (82.7)	2.375 (60.3)				

F