

MISSION-CRITICAL  
INTERCONNECT  
SOLUTIONS



EXTREME TEMPERATURE

# ThermaRex

Cryogenic and High-Temperature Tolerant Connectors,  
Cables, and Conduit Systems

AUGUST 2020



EXTREME TEMPERATURE

# ThermaRex Interconnect Solutions

## Cryogenic and high-temperature tolerant connectors, cables, and conduit systems



### ThermaRex™

#### CONNECTORS

Sensor devices in aerospace engine applications are increasingly exposed to higher temperature operating environments. Environmental sensors in nuclear power reactors—an extremely high temperature and radiation-rich environment—are also exposed to temperature extremes well beyond the capabilities of conventional interconnect devices. Glenair ThermaRex interconnect solutions are designed to survive and excel in high continuous operating temperature application environments up to 600°C. The ThermaRex product family includes connectors, cables, and wire protection conduit systems.

#### 300°C THERMAREX HT CONNECTOR



- Service rating up to 300°C
- Vibration-resistant threaded coupling
- High-temperature ceramic insulators and silicone seals
- Durable stainless steel construction
- Available in Mighty Mouse, and SuperNine® D38999
- Utilizes Glenair Crown Ring contacts

#### 600°C THERMAREX UHT CONNECTOR

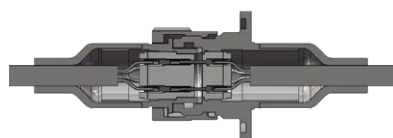

- 300°C to 600°C service range
- Vibration-resistant threaded coupling
- Specialized contacts, laser welds, and metal seals
- Utilizes ultra-high temperature-tolerant Mineral Insulated cable
- Ideal for nuclear and other extreme temperature applications

# HIGH-TEMPERATURE TOLERANT ThermaRex Interconnect Solutions

## Product showcase

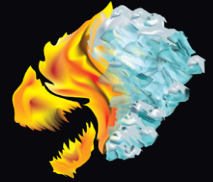

ThermaRex™

### -150°C THERMAREX CRYO CONNECTOR



ThermaRex™  
CRYO

- Dynamic cryogenic connector
- Vibration at -150°C
- Ultra low-temperature Duralectric K seals

### THERMAREX HIGH-TEMPERATURE HERMETIC

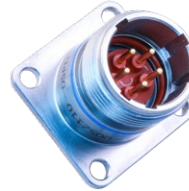

- High-temperature sealing technology maintains  $1 \times 10^{-7}$  leak-rate performance at 300°C

### CROWN RING CONTACTS



- Crimp removable contacts
- Suitable for use at 300°C or higher while maintaining low electrical resistance
- Stainless steel Crown Ring provides compression force on the socket
- Superior vibration resistance
- Higher current carrying capabilities, lower contact resistance

### 300°C THERMAREX WIRE

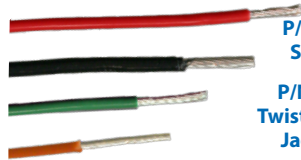

P/N 961-047 -  
Single Wire

P/N 960-2371 -  
Twisted, Shielded,  
Jacketed Pair

- Special nickel-coated copper alloy conductors
- 300°C continuous service
- 24 to 8 AWG, 10 colors of insulation
- Single-wires plus jacketed, shielded, twisted pair available

### 300°C THERMAREX POLYMER-CORE CONDUIT



P/N 120-100,  
Material Code R

- High-temperature-tolerant flexible polymer-core conduit
- All standard colors: Black, clear, orange, blue, yellow
- Qualification test report GT-17-261 available
- 300°C continuous service
- Available with high-temperature braid shield and/or jacket

### 300°C THERMAREX METAL-CORE CONDUIT



P/N 750-216,  
Jacket Code R

- Flexible passivated stainless steel core conduit
- High-temperature-tolerant ThermaRex jacket
- .127" to .250" outer diameter sizes
- 300°C continuous service

### ARMORLITE CF

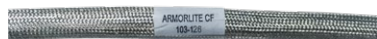

P/N 103-126

- Stainless steel over copper microfilament EMI shield
- High temperature -80°C to 400°C
- Corrosion / harsh environment resistant
- 1000 hour salt spray testing completed
- 70% reduced weight vs. standard braid
- Superb electrical resistance and shielding performance

# HIGH-TEMPERATURE TOLERANT ThermaRex HT SuperNine® Connectors



## High-performance D38999 type solution



- Service rating up to 300°C
- Vibration-resistant threaded coupling
- High-temperature ceramic insulators and silicone seals
- Durable stainless steel construction

How To Order ThermaRex SuperNine connectors						
Sample Part Number	233-273	-20	Z1	17	-26	P N
Series / Basic Part No.	233-273 High-temperature ThermaRex SuperNine connector					
Connector Style	-20 = Receptacle, square flange-mount -24 = Receptacle, jam nut -26 = Plug					
Material/Finish	Z1 = Passivated CRES					
Shell Size	9, 11, 13, 17, 19, 21, 23, 25					
Insert Arrangement	Per M1560. See insert arrangement tables below					
Contact Style	P = Pin contacts S = Socket contacts A = Pin insert, less contacts B = Socket insert, less contacts					
Alternate Polarization*	A, B, C, D, E, N = Normal (IAW MIL-DTL-38999 Series III)					

### MATERIAL / FINISH NOTES

Plug and receptacle shells, coupling nut - Passivated CRES

Insulator - high-grade ceramic dielectric

Grommet, interfacial, and peripheral seals - high-temp silicone

Contacts - copper alloy, gold plated, CRES hood and crown ring on socket contacts

ThermaRex High-Temperature Crown Ring Contact Arrangements (pin mating face shown)				
Suggested high-availability contact arrangements show. Most MIL-STD-1560 arrangements are available, consult factory.				
<b>9-35</b> Contact Size : 22D Qty.: 6 Service Rating: M	<b>11-99</b> Contact Size : 20 Qty.: 7 Service Rating: I	<b>11-35</b> Contact Size : 22D Qty.: 13 Service Rating: M	<b>13-8</b> Contact Size : 20 Qty.: 8 Service Rating: I	<b>13-35</b> Contact Size : 22D Qty.: 22 Service Rating: M
<b>15-97</b> Contact Size : 20 / Quantity: 8 Contact Size : 16 / Quantity: 4 Service Rating: I		<b>17-6</b> Contact Size : 12 Qty.: 6 Service Rating: I		<b>21-24</b> Contact Size : 20 Qty.: 24 Service Rating: I

**HIGH-TEMPERATURE TOLERANT**  
**ThermaRex HT SuperNine® Connectors**  
**High-performance D38999 type solution**



**233-273-24 THERMAREX SUPERNINE RECEPTACLE, JAM NUT**

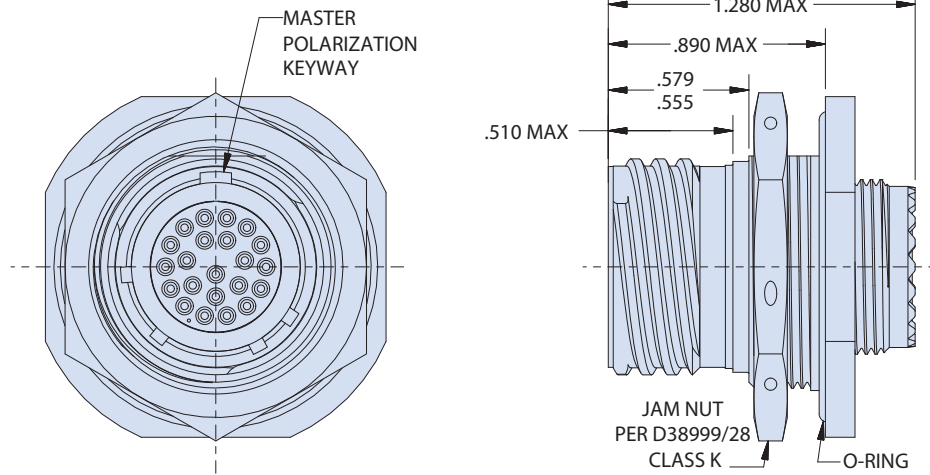

**233-273-26 THERMAREX SUPERNINE PLUG**

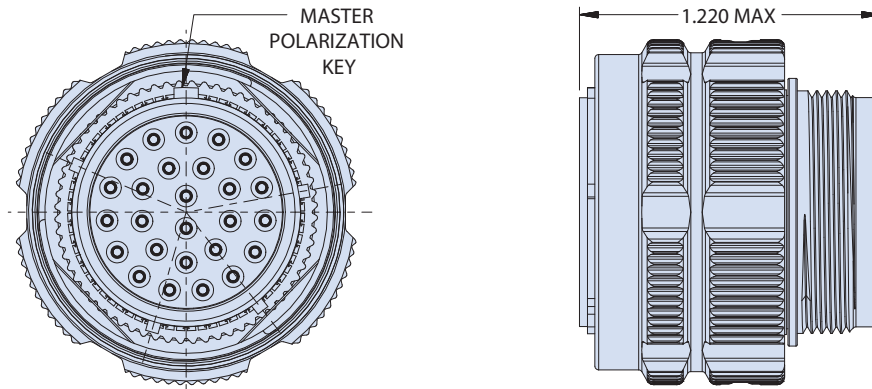

**233-273-20 THERMAREX SUPERNINE RECEPTACLE, SQUARE FLANGE-MOUNT**

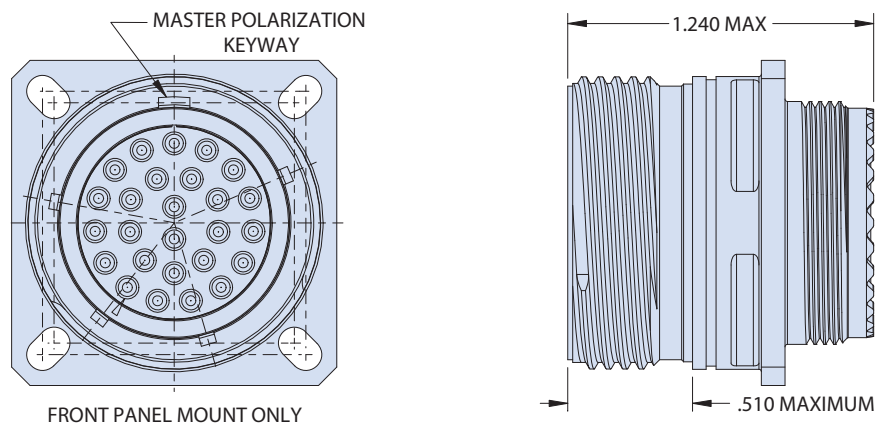



How To Order ThermaRex SuperNine connectors						
Sample Part Number	233-295	-20	Z1	17	-26	P N
Series / Basic Part No.	233-295 Environmental, Thermarex Cryo SuperNine connector					
Connector Style	-20 = Receptacle, square flange-mount -24 = Receptacle, jam nut -26 = Plug					
Material/Finish	ME = Aluminum alloy, electroless nickel Z1 = Stainless steel, passivate					
Shell Size	9, 11, 13, 17, 19, 21, 23, 25					
Insert Arrangement	Per Mil-STD-1560. See insert arrangement tables below					
Contact Style	P = Pin contacts S = Socket contacts A = Pin insert, less contacts B = Socket insert, less contacts					
Alternate Polarization*	A, B, C, D, E, N = Normal (IAW MIL-DTL-38999 Series III)					

### MATERIAL / FINISH NOTES

Plug and receptacle shells, coupling nut - ME = Aluminum alloy, electroless nickel (48-hour salt spray; Z1 = Stainless steel, passivate

Grommet, interfacial, and peripheral seals - Duraelectric™K

Glenair's 233-295 Connector is designed to meet or exceed the mechanical, electrical and environmental requirements of

MIL-DTL-38999 and MIL-STD-1560 operating temperatures are -195°C to +200°C.

Contacts - Pin: copper alloy, gold plated; Socket: copper alloy, gold plated, CRES hood

233-295 plug or receptacle will mate with other D38999 Series III receptacles or plugs having the same shell size, opposite insert arrangement and same mating shell polarization. However, performance at low temperature cannot be guaranteed.

■ Service rating from -195°C to 200°C

■ Vibration-resistant threaded coupling

ThermaRex Cryo Contact Arrangements (pin mating face shown)				
Suggested high-availability contact arrangements show. Most MIL-STD-1560 arrangements are available, consult factory.				
<b>9-35</b> Contact Size : 22D Qty.: 6 Service Rating: M	<b>11-99</b> Contact Size : 20 Qty.: 7 Service Rating: I	<b>11-35</b> Contact Size : 22D Qty.: 13 Service Rating: M	<b>13-8</b> Contact Size : 20 Qty.: 8 Service Rating: I	<b>13-35</b> Contact Size : 22D Qty.: 22 Service Rating: M
<b>15-97</b> Contact Size : 20 / Quantity: 8 Contact Size : 16 / Quantity: 4 Service Rating: I	<b>17-6</b> Contact Size : 12 Qty.: 6 Service Rating: I	<b>21-24</b> Contact Size : 20 Qty.: 24 Service Rating: I		

# CRYOGENIC ThermaRex Cryo SuperNine® Connectors High-performance D38999 type solution

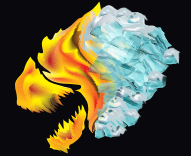

ThermaRex™  
Cryo

## 233-295 SQUARE FLANGE PANEL MOUNT RECEPTACLE

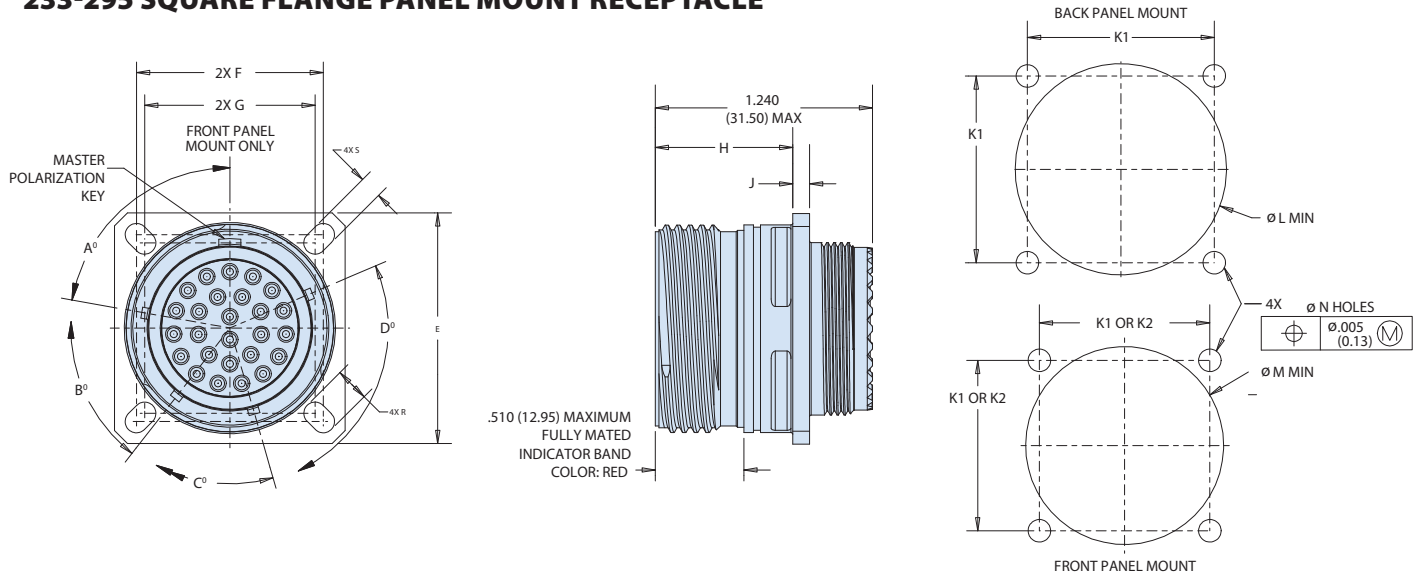

## 233-295 JAM NUT RECEPTACLE

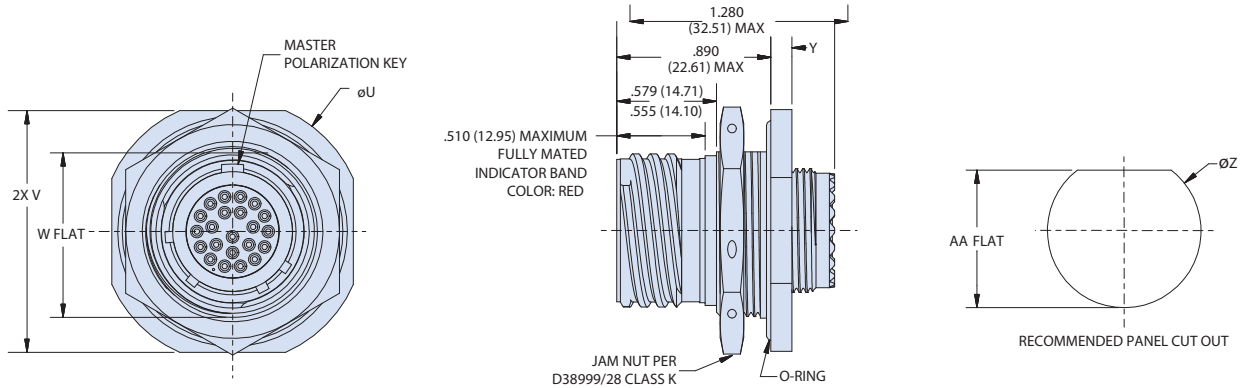

## 233-295 PLUG

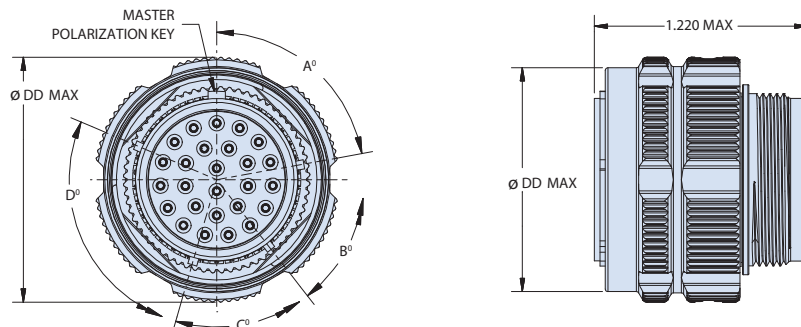

# HIGH-TEMPERATURE TOLERANT ThermaRex HT Series 806 Mil-Aero Connectors Micro-miniature with D38999-caliber performance



- Operating temperature -65°to +300°C
- Vibration-resistant threaded coupling
- High-temperature ceramic insulators and silicone seals
- Durable stainless steel construction

### MATERIAL / FINISH NOTES

Plug and receptacle shells, barrel, coupling nut, jam nut, hex nut - Passivated CRES

Insulator - high-grade ceramic dielectric

Grommet, interfacial seals - high-temp silicone

Contacts - copper alloy, gold plated, CRES hood and crown ring on socket contacts

### Series 806 Arrangements with #20 Contacts (1800 Vac, 7.5 A, pin mating face shown)

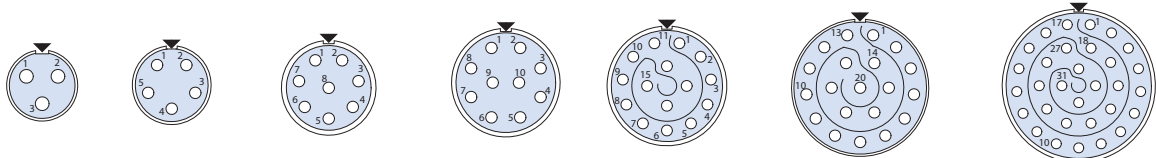

Arrangement No. **8-3**    **9-5**    **10-8**    **11-10**    **12-15**    **14-20**    **16-31**

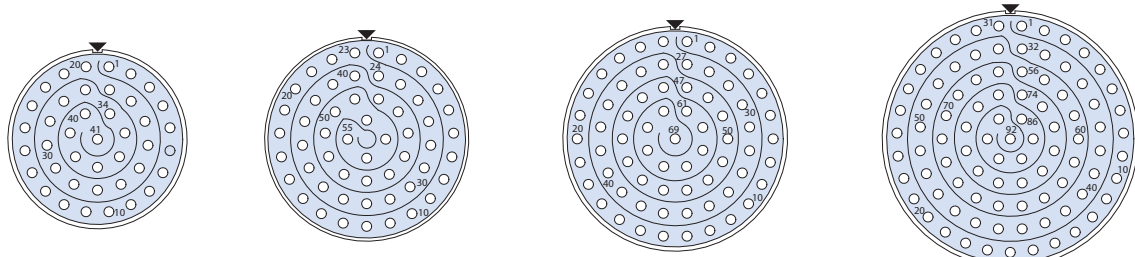

Arrangement No. **18-41**    **20-55**    **22-69**    **24-92**

### Series 806 Arrangements with #22HD Contacts (1300 Vac, 5 A, pin mating face shown)

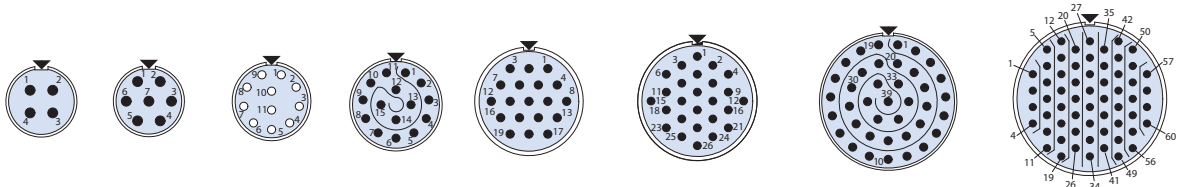

Arrangement No. **8-4**    **8-7**    **9-11**    **10-15**    **11-19**    **12-26**    **14-39**    **16-60**

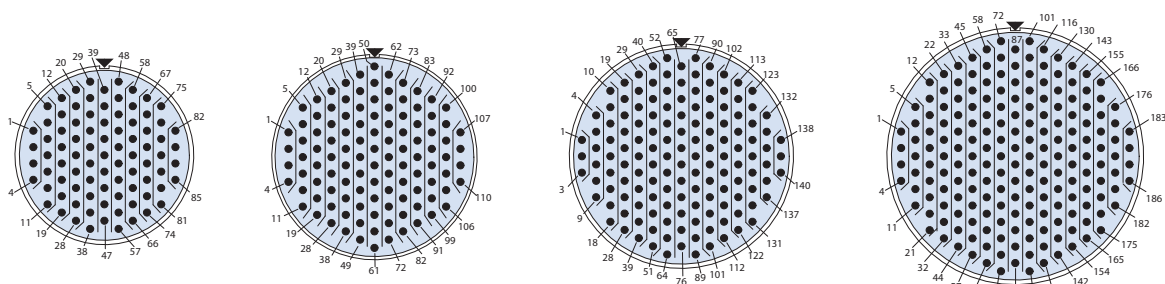

Arrangement No. **18-85**    **20-110**    **22-140**    **24-186**



# HIGH-TEMPERATURE TOLERANT ThermaRex HT Series 806 Mil-Aero Connectors Micro-miniature with D38999-caliber performance

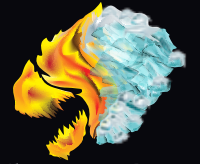

ThermaRex™  
HT

## SERIES 806 MIL-AERO PLUG

How To Order ThermaRex Series 806 Mil-Aero Plug							
	SAMPLE PART NUMBER	806-042	Z1	11-19	S	M	A
Series / Basic Part No.	806-042 High-temperature ThermaRex Series 806 plug						
Material/Finish	Z1 = Passivated CRES						
Shell Size/Insert Arr.	Per 806-015, See tables						
Contact Style	P = Pin A = Pin connector, less contacts S = Socket B = Socket connector, less contacts						
Shell Style	M = Metric accessory thread B = Banding platform						
Polarization Keyway Code	A, B, C, D, E, F						

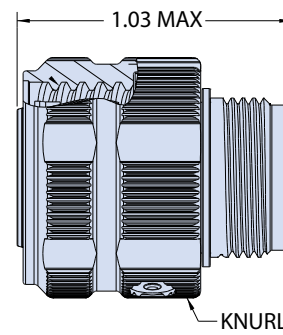
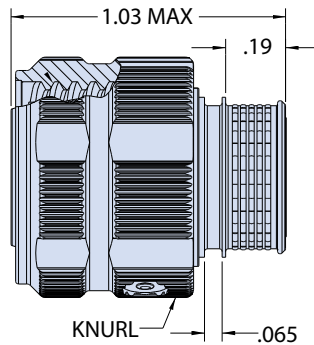
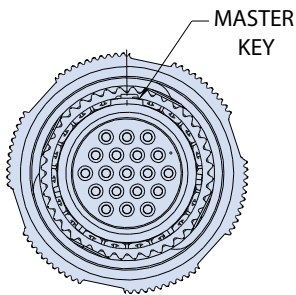

## SERIES 806 MIL-AERO JAM NUT RECEPTACLE WITH PCB STANDOFF

How To Order ThermaRex Series 806 Mil-Aero Jam Nut Receptacle						
	SAMPLE PART NUMBER	806-041	Z1	11-19	P	N
Series / Basic Part No.	806-041 High-temperature ThermaRex Series 806 jam nut receptacle with PCB standoff					
Material/Finish	Z1 = Passivated CRES					
Shell Size/Insert Arr.	Per 806-015, See tables					
Contact Style	P = Pin contacts only					
Polarization Keyway Code	A, B, C, D, E, F					

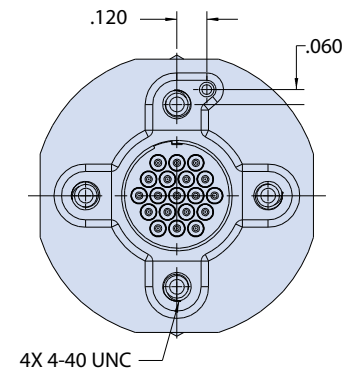
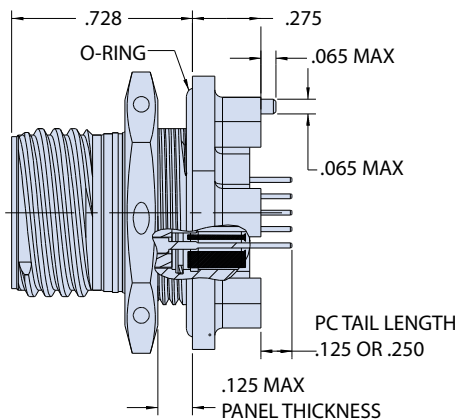
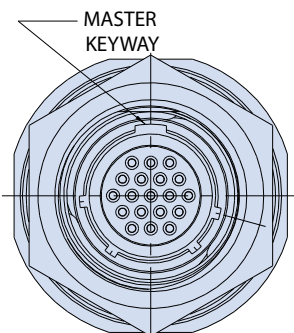

# HIGH-TEMPERATURE TOLERANT ThermaRex HT Series 806 Mil-Aero Connectors Micro-miniature with D38999-caliber performance



## SERIES 806 MIL-AERO SQUARE FLANGE RECEPTACLE

How To Order ThermaRex Series 806 Mil-Aero Square Flange Receptacle							
	SAMPLE PART NUMBER	806-052	Z1	11-19	S	M	T A
Series / Basic Part No.	806-052 High-temperature ThermaRex Series 806 square-flange receptacle						
Material/Finish	Z1 = Passivated CRES						
Shell Size/Insert Arr.	Per 806-015, See tables						
Contact Style	P = Pin A = Pin connector, less contacts S = Socket B = Socket connector, less contacts						
Shell Style	M = Metric accessory thread B = Banding platform						
Panel Mounting	T = Thru-hole						
Polarization Keyway Code	A, B, C, D, E, F						

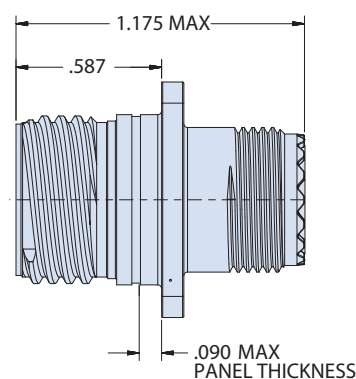
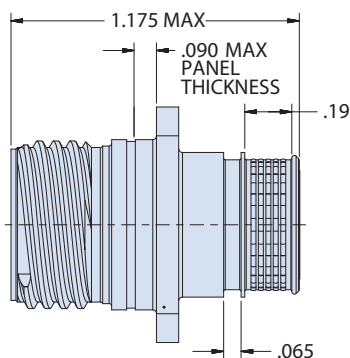
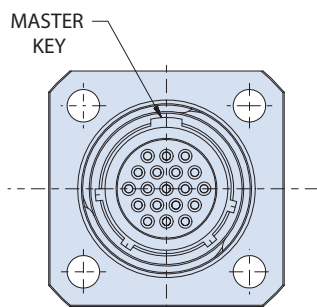

# HIGH-TEMPERATURE TOLERANT ThermaRex HT Series 806 Mil-Aero Connectors Micro-miniature with D38999-caliber performance



## SERIES 806 MIL-AERO JAM NUT RECEPTACLE

How To Order ThermaRex Series 806 Mil-Aero Jam Nut Receptacle							
	SAMPLE PART NUMBER	806-053	Z1	11-19	S	M	A
Series / Basic Part No.	806-053 High-temperature ThermaRex Series 806 jam-nut receptacle						
Material/Finish	Z1 = Passivated CRES						
Shell Size/Insert Arr.	Per 806-015, See tables						
Contact Style	P = Pin    A = Pin connector, less contacts S = Socket    B = Socket connector, less contacts						
Shell Style	M = Metric accessory thread    B = Banding platform						
Polarization Keyway Code	A, B, C, D, E, F						

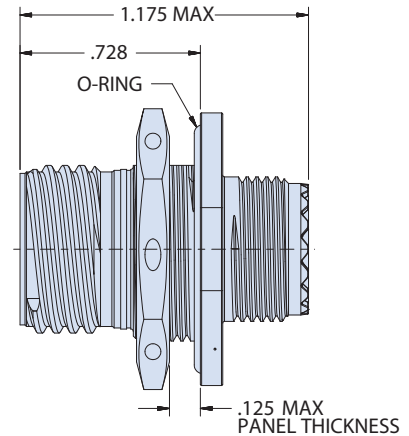
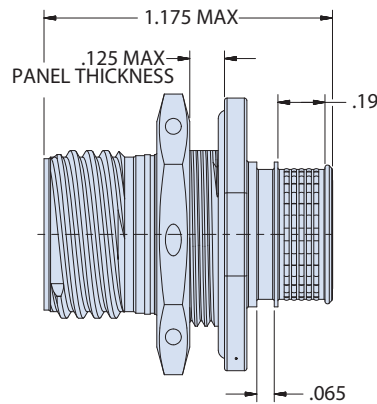
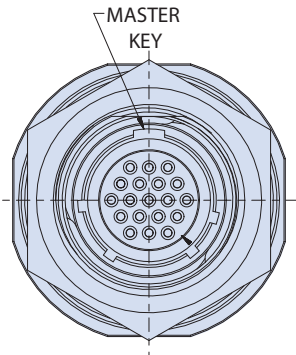

# Series 806 Mil-Aero Connectors

## 806-060 ThermaRex Cryogenic Plug

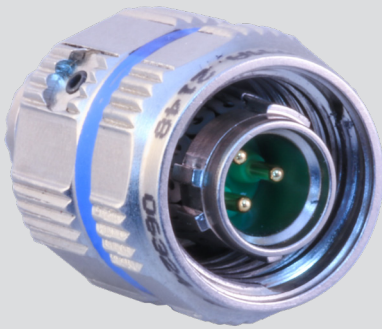

Extreme low-temperature 806-060 ThermaRex Cryo plug connectors are rated to perform in temperatures as low as -195° C. Intended for use in sub-zero harsh applications such as space vehicles or aircraft zones subject to high altitude, while providing size and weight savings compared to conventional aerospace-grade circular connectors. Rugged ratchet mechanism and unique triple-start mating thread provide improved de-coupling resistance under vibration. Shell styles include integrated metric accessory thread or band platform.

### Features

- Operating temperature -195°C to +200°C
- Special low-temperature 300G shock and aerospace vibration testing while submerged in liquid nitrogen
- Triple-start stub ACME mating thread
- High density #22HD and #20HD arrangements for reduced size and weight plus #16, #12 and #8 standard and hybrid contact layouts
- Aerospace-grade materials, construction
- Band platform or accessory threads

### Specifications

- Dielectric withstanding voltage  
#22HD contacts: 1300 VAC  
#20HD contacts: 1800 VAC  
#16 contacts: varies, contact factory  
#12 contacts: varies, contact factory  
#8 contacts: varies, contact factory
- Mating durability: 500 cycles
- Mechanical shock: EIA-364-27, 300g.
- Vibration (sine): MIL-DTL-38999M, 60g.
- Vibration (random) EIA-364-28 Condition VI, Letter J, 43.92 Grms, +200°C
- High Impact shock: MIL-S-901 Grade A
- Humidity: EIA-364-31 Method 4
- Salt spray (dynamic): EIA-364-26, 500 hours (96 hours for nickel-plated versions)
- Fluid immersion: EIA-364-10
- Altitude immersion: EIA-364-03 75,000 feet altitude
- Indirect Lightning Strike: EIA-364-75 Type B Level 2 10kA Peak

### Connector Construction

- Shell: passivated CRES or Aluminum Alloy
- Contacts: copper alloy, gold plate
- Insulator: high grade rigid dielectric
- Interfacial seal, grommet: Duraelectric K low-temp silicone

How To Order ThermaRex Series 806 Mil-Aero Plug							
SAMPLE PART NUMBER		806-060	-Z1	11-19	S	M	A
Series / Basic Part No.	806-060 ThermaRex Cryogenic Plug						
Material/Finish	ME = Aluminum Alloy / Electroless Nickel Z1 = Stainless Steel / Passivated						
Shell Size/Insert Arr.	See Table I						
Contact Style	A = Pin connector less contacts		P = Pin				
	B = Socket connector Less contacts		S = Socket				
Shell Style	M = Metric (Accessory Thread) B = Band (platform for attaching cable shield.)						
Polarization	A, B, C, D, E, F						

Table I: Shell Size - Insert Arrangement																	
Contact Layout	Number of Contacts					Contact Layout	Number of Contacts					Contact Layout	Number of Contacts				
	22HD	20HD	16	12	8		22HD	20HD	16	12	8		22HD	20HD	16	12	8
7-3	3					22-69		69				16-2				2	
8-4	4					24-92		92				18-3				3	
8-7	7					8-1			1			20-4				4	
9-11	11					10-2			2			22-5				5	
10-15	15					11-4			4			24-8				8	
11-19	19					12-5			5			10-8A	6		2		
12-26	26					14-7			7			11-13	11		2		
14-39	39					16-12			12			12-27	26		1		
16-60	60					18-15			15			14-21	17		4		
18-85	85					20-22			22			16-41	37		4		
20-110	110					22-24			24			18-59	55		4		
22-140	140					24-35			35			11-14	13			1	
24-186	186					9-1				1		12-14	12			2	
8-3		3				12-2				2		14-22	20			2	
9-5		5				14-3				3		16-42	40			2	
10-8		8				16-4				4		18-62	60			2	
11-10		10				16-7				7		14-20A	19			1	
12-15		15				18-8				8		16-22	20			2	
14-20		20				20-11				11		18-21	18			3	
16-31		31				22-13				13		20-28	24			4	
18-41		41				24-19				19		22-44	40			4	
20-55		55				10-1					1	24-97	93			4	

CRYOGENIC, MICRO MINIATURE CIRCULAR

# Series 806 Mil-Aero Connectors

## 806-060 ThermoRex Cryogenic Plug

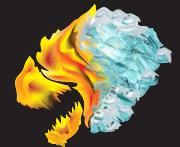

ThermoRex™  
CRYO

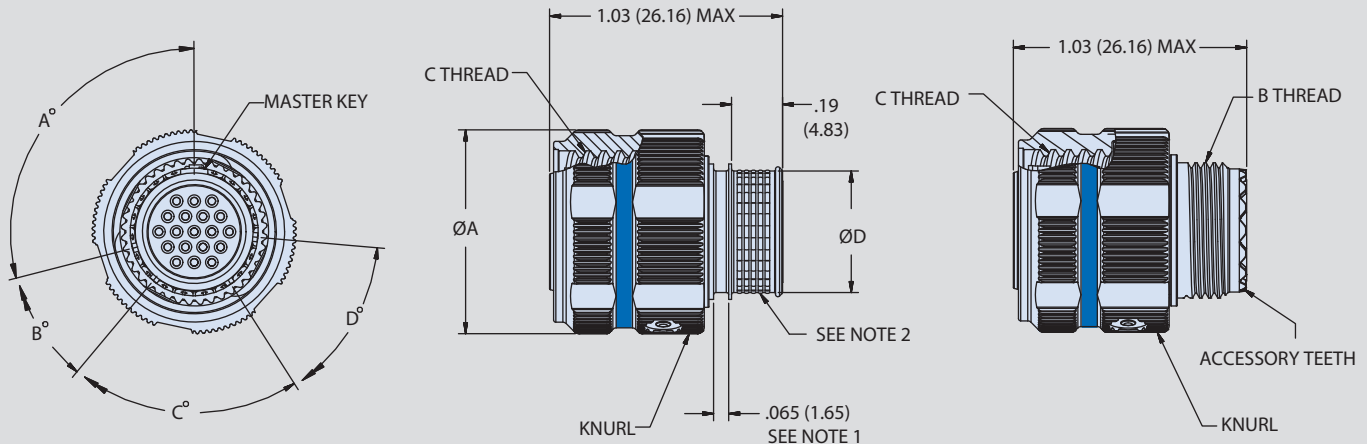

BAND PLATFORM

METRIC ACCESSORY THREAD

### 806-060 Dimensions

SHELL SIZE	ØA MAX	B THREAD	C MATING THREAD	Ø D
7	.606 (15.39)	M8X 1-6g-.100R	.4375-.067P-.2L-TS-2B	.267 (6.78)
8	.676 (17.17)	M10 X 1-6g-.100R	.500-.067P-.2L-TS-2B	.327 (8.31)
9	.774 (19.66)	M12 X 1-6g-.100R	.562-.067P-.2L-TS-2B	.406 (10.31)
10	.832 (21.13)	M14 X 1-6g-.100R	.625-.067P-.2L-TS-2B	.484 (12.29)
11	.890 (22.61)	M15 X 1-6g-.100R	.688-.067P-.2L-TS-2B	.524 (13.31)
12	.950 (24.13)	M17 X 1-6g-.100R	.750-.067P-.2L-TS-2B	.603 (15.32)
14	1.110 (28.19)	M19 X 1-6g-.100R	.875-.067P-.2L-TS-2B	.681 (17.30)
16	1.170 (29.72)	M22 X 1-6g-.100R	1.000-.067P-.2L-TS-2B	.782 (19.86)
18	1.350 (34.29)	M25 X 1-6g-.100R	1.1250-.067P-.2L-TS-2B	.899 (22.83)
20	1.470 (37.34)	M28 X 1-6g-.100R	1.250-.067P-.2L-TS-2B	1.043 (26.49)
22	1.600 (40.64)	M31 X 1-6g-.100R	1.375-.067P-.2L-TS-2B	1.155 (29.34)
24	1.710 (43.43)	M34 X 1-6g-.100R	1.500-.067P-.2L-TS-2B	1.273 (32.33)

#### NOTES:

1. Boot groove for use with overmolded strain relief or 809-060 heat shrink boots
2. Terminate shield with Glenair Band-Master ATS tool 601-108 and Glenair Nanoband

# Series 806 Mil-Aero Connectors

## 806-061 ThermaRex Cryogenic Jam Nut Receptacle



Extreme low-temperature 806-061 ThermaRex receptacle connectors are rated to perform in temperatures as low as -195° C. Intended for use in sub-zero harsh applications such as space vehicles or aircraft zones subject to high altitude, while providing size and weight savings compared to conventional aerospace-grade circular connectors. Unique triple-start mating thread provides improved de-coupling resistance under vibration. Jam nut receptacle styles include integrated metric accessory thread or band platform.

### Features

- Operating temperature -195°C to +200°C
- Special low-temperature 300G shock and aerospace vibration testing while submerged in liquid nitrogen
- Triple-start stub ACME mating thread
- High density #22HD and #20HD arrangements for reduced size and weight plus #16, #12 and #8 standard and hybrid contact layouts
- Aerospace-grade materials, construction
- Band platform or accessory threads

### Specifications

- Dielectric withstanding voltage  
#22HD contacts: 1300 VAC  
#20HD contacts: 1800 VAC  
#16 contacts: varies, contact factory  
#12 contacts: varies, contact factory  
#8 contacts: varies, contact factory
- Mating durability: 500 cycles
- Mechanical shock: EIA-364-27, 300g.
- Vibration (sine): MIL-DTL-38999M, 60g.
- Vibration (random) EIA-364-28 Condition VI, Letter J, 43.92 Grms, +200°C
- High Impact shock: MIL-S-901 Grade A
- Humidity: EIA-364-31 Method 4
- Salt spray (dynamic): EIA-364-26, 500 hours (96 hours for nickel-plated versions)
- Fluid immersion: EIA-364-10
- Altitude immersion: EIA-364-03 75,000 feet altitude
- Indirect Lightning Strike: EIA-364-75 Type B Level 2 10kA Peak

### Connector Construction

- Shell, hex nut: passivated CRES or Aluminum Alloy
- Contacts: copper alloy, gold plate
- Insulator: high grade rigid dielectric
- Interfacial seal, grommet: Duraelectric K low-temp silicone

How To Order ThermaRex Series 806 Mil-Aero Jam-nut Receptacle							
SAMPLE PART NUMBER		806-061	-Z1	11-19	S	M	A
Series / Basic Part No.	806-061 ThermaRex Cryogenic Jam Nut Receptacle						
Material/Finish	ME = Aluminum Alloy / Electroless Nickel Z1 = Stainless Steel / Passivated						
Shell Size/Insert Arr.	See Table I						
Contact Style	A = Pin connector less contacts B = Socket connector Less contacts			P = Pin S = Socket			
Shell Style	M = Metric (Accessory Thread) B = Band (platform for attaching cable shield.)						
Polarization	A, B, C, D, E, F						

Table I: Shell Size - Insert Arrangement

Contact Layout	Number of Contacts					Contact Layout	Number of Contacts					Contact Layout	Number of Contacts				
	22HD	20HD	16	12	8		22HD	20HD	16	12	8		22HD	20HD	16	12	8
7-3	3					22-69	69				16-2					2	
8-4	4					24-92	92				18-3					3	
8-7	7					8-1		1			20-4					4	
9-11	11					10-2		2			22-5					5	
10-15	15					11-4		4			24-8					8	
11-19	19					12-5		5			10-8A	6		2			
12-26	26					14-7		7			11-13	11		2			
14-39	39					16-12		12			12-27	26		1			
16-60	60					18-15		15			14-21	17		4			
18-85	85					20-22		22			16-41	37		4			
20-110	110					22-24		24			18-59	55		4			
22-140	140					24-35		35			11-14	13			1		
24-186	186					9-1			1		14-22	20			2		
8-3		3				12-2			2		12-14	12			2		
9-5		5				14-3			3		16-42	40			2		
10-8		8				16-4			4		18-62	60			2		
11-10		10				16-7			7		14-20A	19				1	
12-15		15				18-8			8		16-22	20				2	
14-20		20				20-11			11		18-21	18				3	
16-31		31				22-13			13		20-28	24				4	
18-41		41				24-19			19		22-44	40				4	
20-55		55				10-1			1		24-97	93				4	

# Series 806

# Mil-Aero Connectors

## 806-061 ThermoRex Cryogenic Jam Nut Receptacle

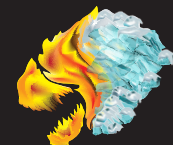

ThermoRex™  
CRYO

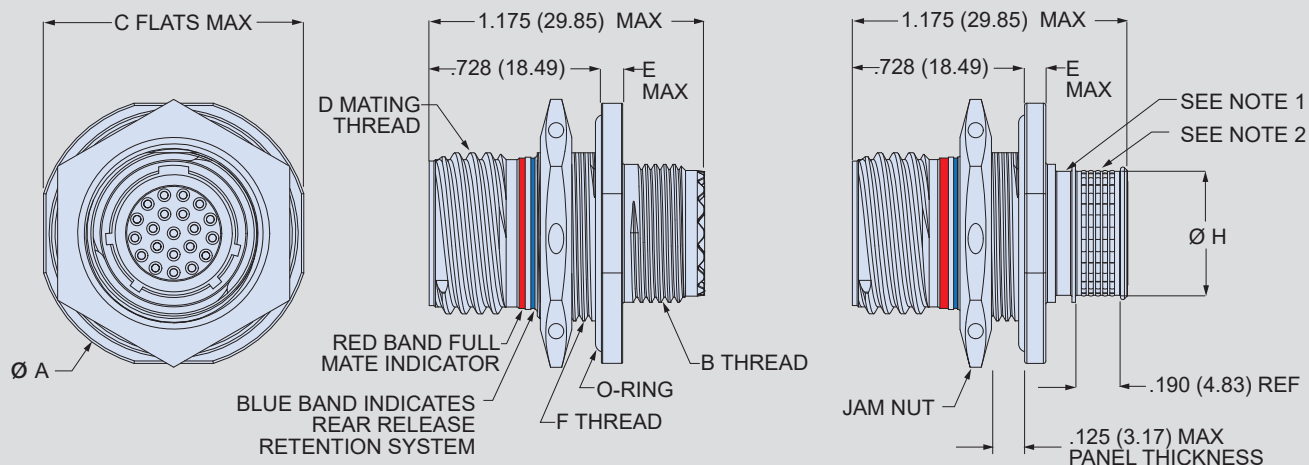

**SHELL STYLE M**  
METRIC ACCESSORY THREAD

**SHELL STYLE B**  
NANO BAND PLATFORM

### Dimensions

Shell Size	ØA Max	B Thread	C Max	D Mating Thread	E Max	F Thread	ØH
7	.848 (21.54)	M8X 1-6g-.100R	.908 (23.06)	.4375-.067P-.2L-TS-2A	0.100 (2.54)	M13 X 1-6g-.100R	.265 (6.73)
8	.980 (24.89)	M10 X 1-6g-.100R	.920 (23.37)	.5000-.067P-.2L-TS-2A		M15 X 1-6g-.100R	.327 (8.31)
9	1.040 (26.42)	M12 X 1-6g-.100R	.980 (24.89)	.5625-.067P-.2L-TS-2A		M16 X 1-6g-.100R	.406 (10.31)
10	1.110 (28.19)	M14 X 1-6g-.100R	1.050 (26.67)	.6250-.067P-.2L-TS-2A		M18 X 1-6g-.100R	.484 (12.29)
11	1.160 (29.46)	M15 X 1-6g-.100R	1.110 (28.19)	.6875-.067P-.2L-TS-2A		M19 X 1-6g-.100R	.524 (13.31)
12	1.230 (31.24)	M17 X 1-6g-.100R	1.170 (29.72)	.7500-.067P-.2L-TS-2A		M21 X 1-6g-.100R	.603 (15.32)
14	1.360 (34.54)	M19 X 1-6g-.100R	1.320 (33.53)	.8750-.067P-.2L-TS-2A		M24 X 1-6g-.100R	.681 (17.30)
16	1.515 (38.48)	M22 X 1-6g-.100R	1.444 (36.68)	1.000-.067P-.2L-TS-2A		M27 X 1-6g-.100R	.782 (19.86)
18	1.610 (40.89)	M25 X 1-6g-.100R	1.570 (39.88)	1.1250-.067P-.2L-TS-2A		M30 X 1-6g-.100R	.899 (22.83)
20	1.850 (46.99)	M28 X 1-6g-.100R	1.760 (44.70)	1.250-.067P-.2L-TS-2A		M34 X 1-6g-.100R	1.043 (26.49)
22	2.010 (51.05)	M31 X 1-6g-.100R	1.913 (48.59)	1.3750-.067P-.2L-TS-2A	0.128 (3.25)	M37 X 1-6g-.100R	1.155 (29.34)
24	2.195 (55.75)	M34 X 1-6g-.100R	2.070 (52.58)	1.500-.067P-.2L-TS-2A		M41 X 1-6g-.100R	1.273 (32.33)

### Recommended Mounting Hole

SHELL SIZE	K		J	
	+0.005 (0.13)	0.000 (0.00)	+0.005 (0.13)	0.00 (0.00)
7	.224 (5.69)		.522 (13.26)	
8	.256 (6.50)		.601 (15.27)	
9	.287 (7.29)		.640 (16.26)	
10	.318 (8.08)		.719 (18.26)	
11	.350 (8.89)		.759 (19.28)	
12	.381 (9.68)		.837 (21.26)	
14	.443 (11.25)		.955 (24.26)	
16	.505 (12.83)		1.073 (27.25)	
18	.568 (14.43)		1.192 (30.28)	
20	.630 (16.00)		1.349 (34.26)	
22	.693 (17.60)		1.467 (37.26)	
24	.755 (19.18)		1.624 (41.25)	

Jam-Nut Cutout

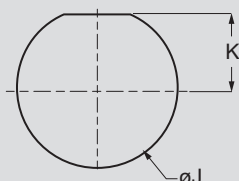

### NOTES:

1. Boot groove for use with overmold strain relief or 809-060 heat shrink boots
2. Terminate shield with Glenair Band-Master ATS tool 601-108 and Glenair Nanoband

# LOW-TEMPERATURE TOLERANT ThermaRex Cryogenic 806 Mil-Aero Connectors Micro-miniature with D38999-caliber performance



## SERIES 806 MIL-AERO JAM NUT PCB STANDOFF RECEPTACLE

How To Order ThermaRex Series 806 Mil-Aero Square Flange Receptacle							
	SAMPLE PART NUMBER	806-085	ME	11-19	S	1	A
Series / Basic Part No.	806-085 Cryogenic ThermaRex Series 806 jam nut PCB standoff receptacle						
Material/Finish	ME = Aluminum alloy, electroless nickel (96-hour salt spray) Z1 = Stainless steel, passivate						
Shell Size/Insert Arr.	Per 806-015, See tables						
Contact Type	P = Pin E = Solder cup, pin S = Socket F = Solder cup, SKT						
PC Tail Length	1 = .125±.025 Solder Cup = Omit						
Polarization Keyway Code	A, B, C, D, E, F						

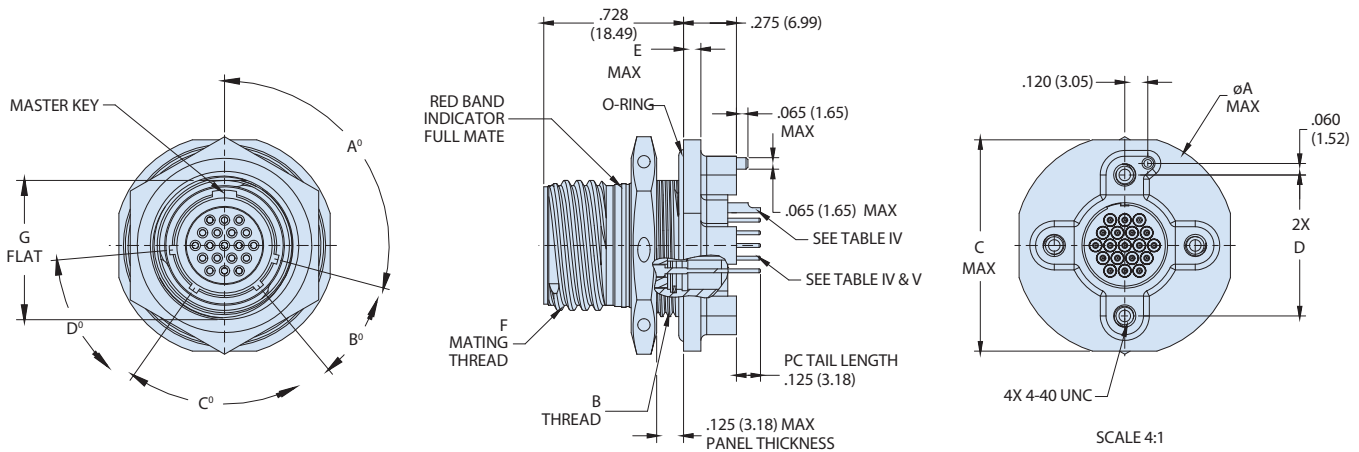



# LOW-TEMPERATURE TOLERANT ThermaRex Cryogenic 806 Mil-Aero Connectors Micro-miniature with D38999-caliber performance



## SERIES 806 MIL-AERO SQUARE FLANGE PCB STANDOFF RECEPTACLE

How To Order ThermaRex Series 806 Mil-Aero Square Flange Receptacle							
SAMPLE PART NUMBER	<b>806-086</b>	<b>ME</b>	<b>11-19</b>	<b>S</b>	<b>1</b>	<b>T</b>	<b>A</b>
Series / Basic Part No.	<b>806-086</b> Cryogenic ThermaRex Series 806 square flange PCB standoff receptacle						
Material/Finish	<b>ME</b> = Aluminum alloy, electroless nickel (96-hour salt spray) <b>Z1</b> = Stainless steel, passivate						
Shell Size/Insert Arr.	Per 806-015, See tables						
Contact Type	<b>P</b> = Pin <b>E</b> = Solder cup, pin <b>S</b> = Socket <b>F</b> = Solder cup, SKT						
PC Tail Length	<b>1</b> = .125±.025   Solder Cup = Omit						
Panel Mounting Hole Style	<b>T</b> = Thru hole <b>C</b> = Clinch nuts for rear panel mounting, 4-40, M45938/6-4C						
Polarization Keyway Code	<b>A, B, C, D, E, F</b>						

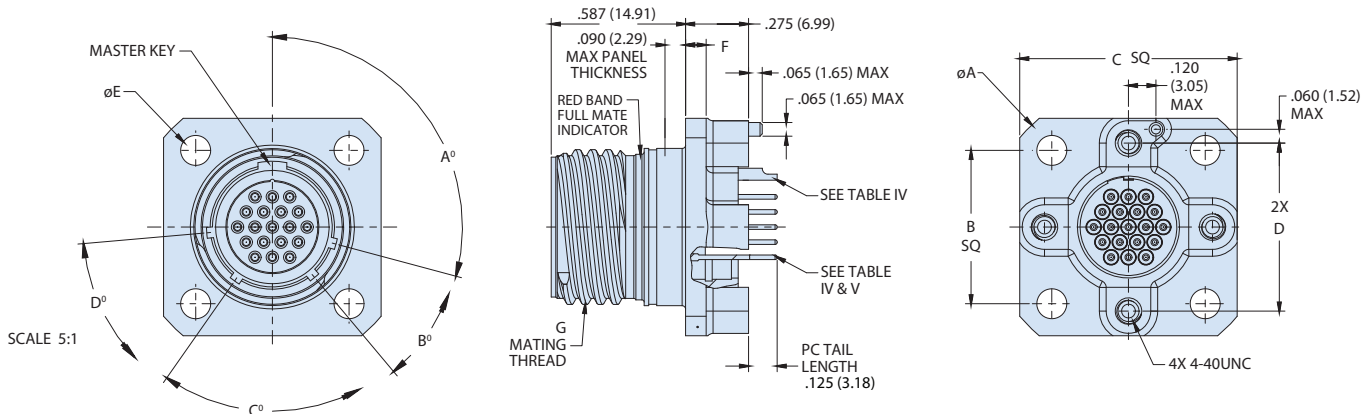

# HIGH-TEMPERATURE TOLERANT ThermaRex HT Series 79 Micro-Crimp



## High-Performance Crimp-Contact How To Order / Contact Arrangements



How To Order ThermaRex Series 79 connectors					
Sample Part Number	797	-756	S	H-29P7	E
Series / Basic Part No.	797 High-temperature ThermaRex Series 79 crimp-contact rectangular				
Connector Type	-756 = Plug -757 = Receptacle				
Contact Type	S = Socket (for -756 Plug connectors) P = Pin (for -757 Receptacle connectors)				
Insert Arrangement	Per 799-009. See insert arrangement tables below				
EMI Spring Option	E = With EMI spring N = No EMI spring (Only available on plug connectors)				

- Service rating up to 300°C
- Vibration-resistant threaded coupling
- High-temperature ceramic insulators and silicone seals
- Durable stainless steel construction
- No EMI groove and spring option for connector with insert arrangements G-33 or G-13P3.

ThermaRex High-Temperature Crown Ring Contact Arrangements (pin mating face shown)				
A-5 5 #23	B-2P2 / B-2W2 2 #16	B-9 9 #23	C-13 13 #23	D-15 15 #23
D-3P3 / D-3W3 3 #16	D-7P2 / D-7W2 5 #23 / 2 #16	E-11P2 / E-11W2 9 #23 / 2 #16	E-19 19 #23	
E-7P3 / 4 #23 3 #16	F-15P2 / F-15W2 13 #23 / 2 #16	F-23 23 #23		
F-5P5 / F-5W5 5 #16			G-33 33 #23	
H-10P4 / H-10W4 6 #23 / 4 #12			H-29P7 22 #23 / 7 #16	
H-36P2 / H-36W2 34 #23 / 2 #12			H-54P2 / H-54W2 52 #23 / 2 #16	

# HIGH-TEMPERATURE TOLERANT ThermaRex HT Series 79 Micro-Crimp

## High-Performance Crimp-Contact How To Order / Contact Arrangements

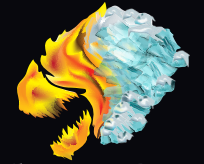

ThermaRex™  
HT

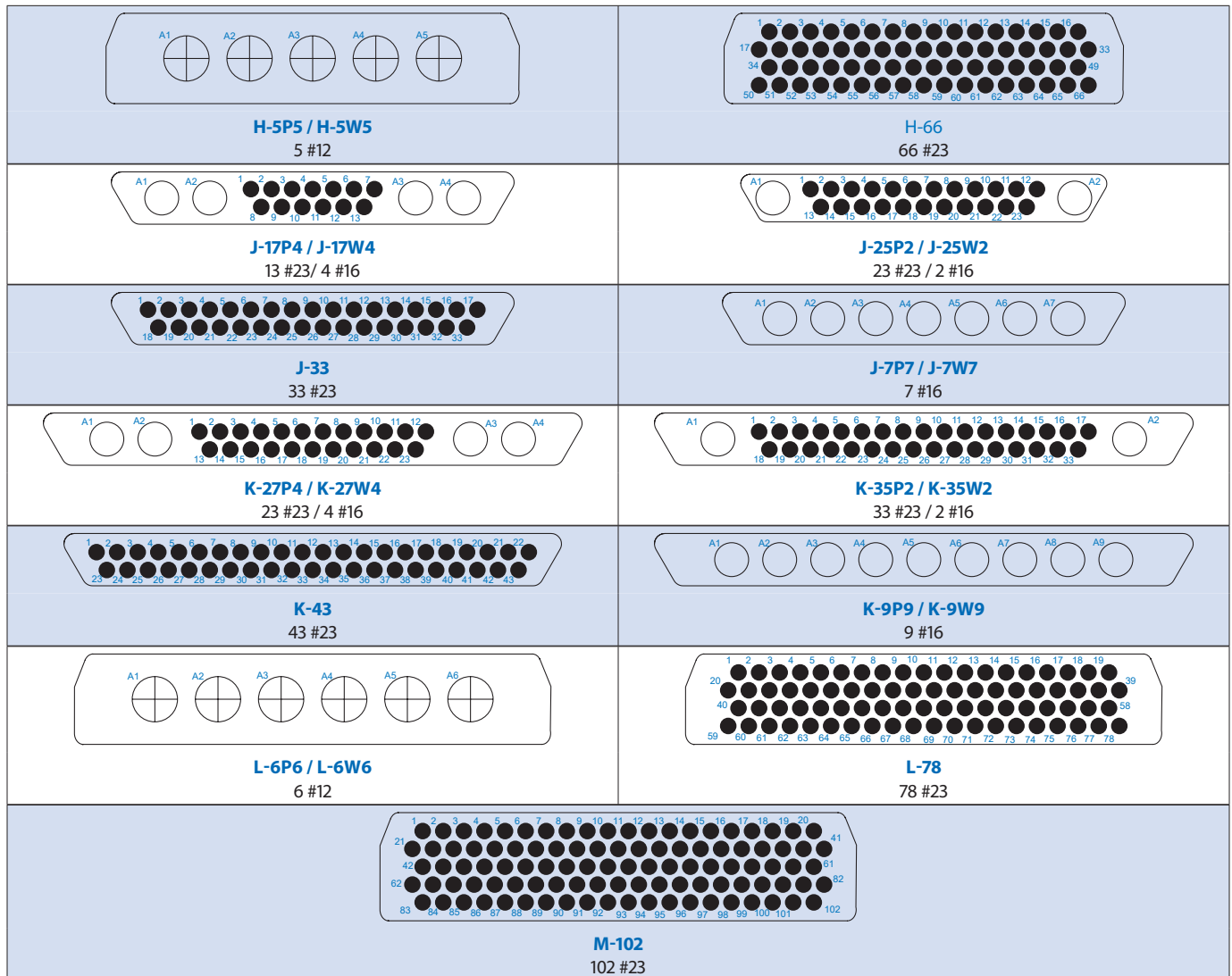

### MATERIAL / FINISH NOTES

Housing, Float Mount Hardware, Guide Socket - Stainless Steel / Passivated  
Pin and Socket Contact - Copper Alloy / Gold Plated  
Socket Hood - Stainless Steel / Passivated  
Insulators - High Grade Ceramic / N/A  
Grommet and Interfacial Seal - High Temperature Silicone / N/A  
Retainer Clip Stainless Steel / N/A  
EMI Spring - Stainless Steel / Gold Plated

### ELECTRICAL PERFORMANCE

Contacts: Size 23 = 5 Amps Max. / Size 16 = 13 Amps Max./ Size 12 = 23 Amps Max.  
DWV - 500 Vac, with 5 Milliampere Max. leakage  
Insulation Resistance Resistance - 5,000 Megohms Max.

Operating Temperature: -65°C to +300°C

### BLIND MATE MISALIGNMENT ALLOWANCE

Shell Sizes A, B, C, D, E, F, G, J, K:  
±.040 (1.02) Allowable misalignment from centerline  
Shell Sizes H, L:  
±.040 (1.02) Allowable misalignment from centerline  
Shell Size M:  
±.050 (1.27) allowable misalignment from centerline

# HIGH-TEMPERATURE TOLERANT ThermaRex HT Series 79 Micro-Crimp High-Performance Crimp-Contact 797-756 Plug Details



## CROSS-SECTIONAL VIEW AND HARDWARE

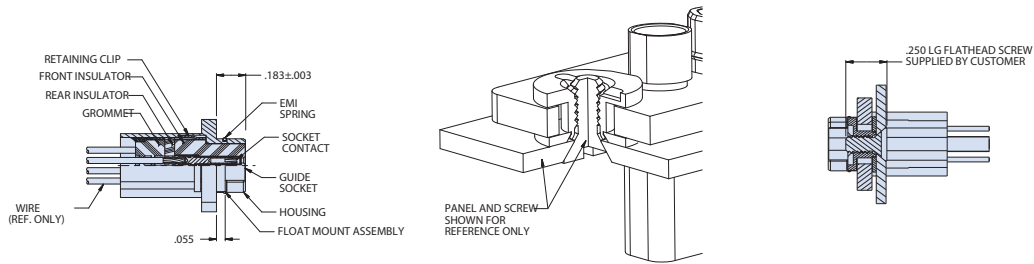

CONNECTOR SUPPLIED WITH NON-REMOVABLE GUIDE POST FOR BLIND MATE APPLICATION.  
FLOAT MOUNT BUSHING HAS SHELL SIZES "M", "L" & "H" WITH #4-40 UNC-2B THREAD. ALL OTHER SIZES HAVE #2-56 UNC-2B THREAD.

## SHELL SIZES A, B, C, D, E, F, J, K

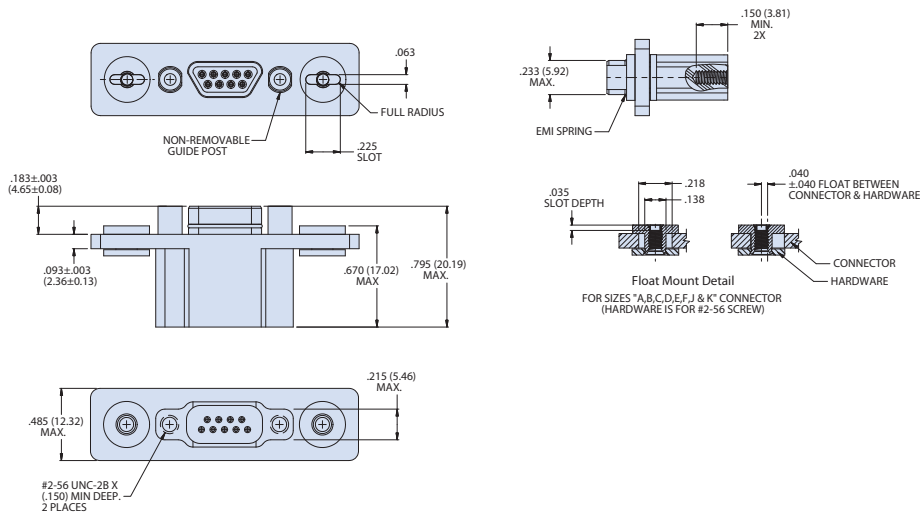

## SHELL SIZE G

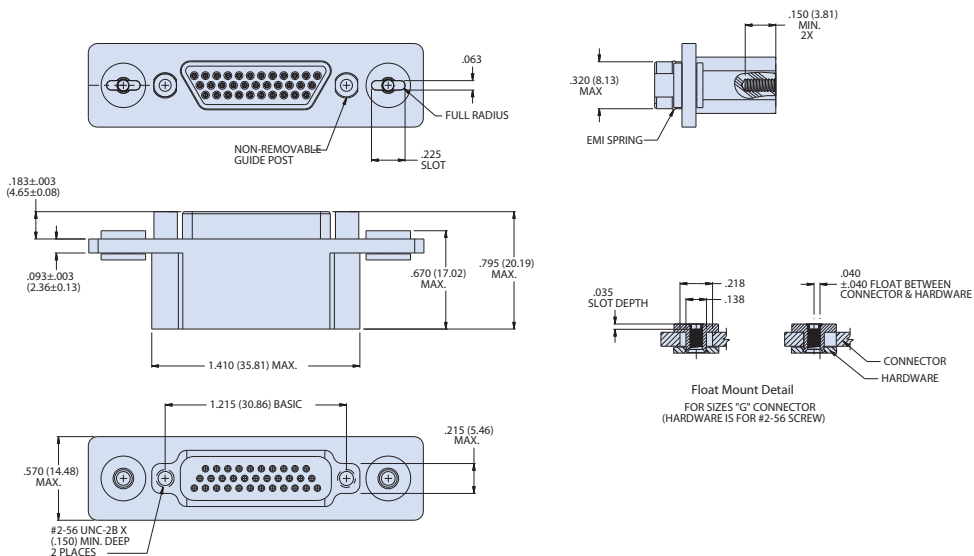

# HIGH-TEMPERATURE TOLERANT ThermaRex HT Series 79 Micro-Crimp High-Performance Crimp-Contact 797-756 Plug Details

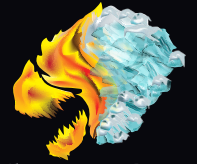

ThermaRex™  
HT

## SHELL SIZES H AND L

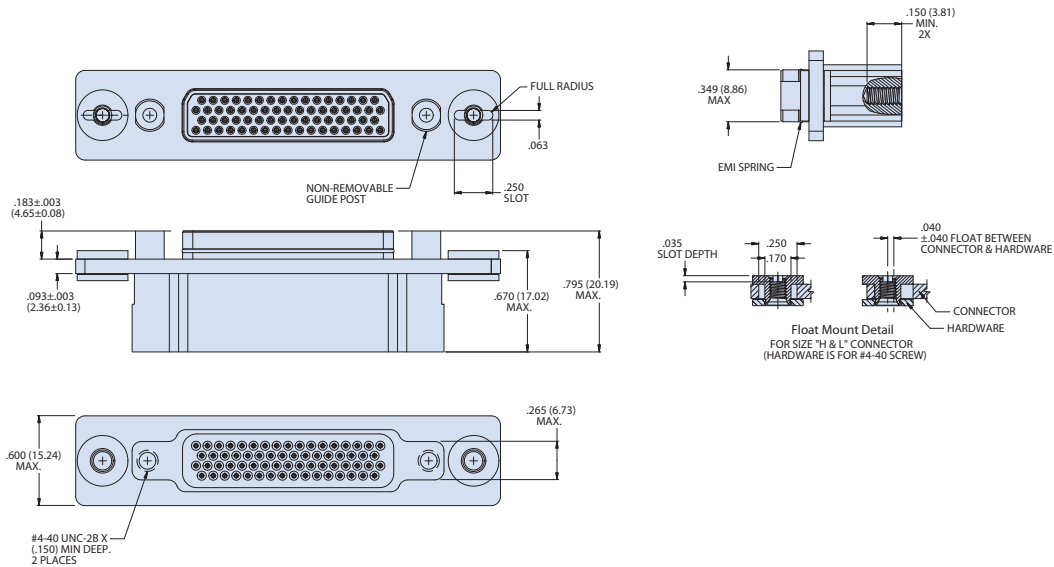

## SHELL SIZE M

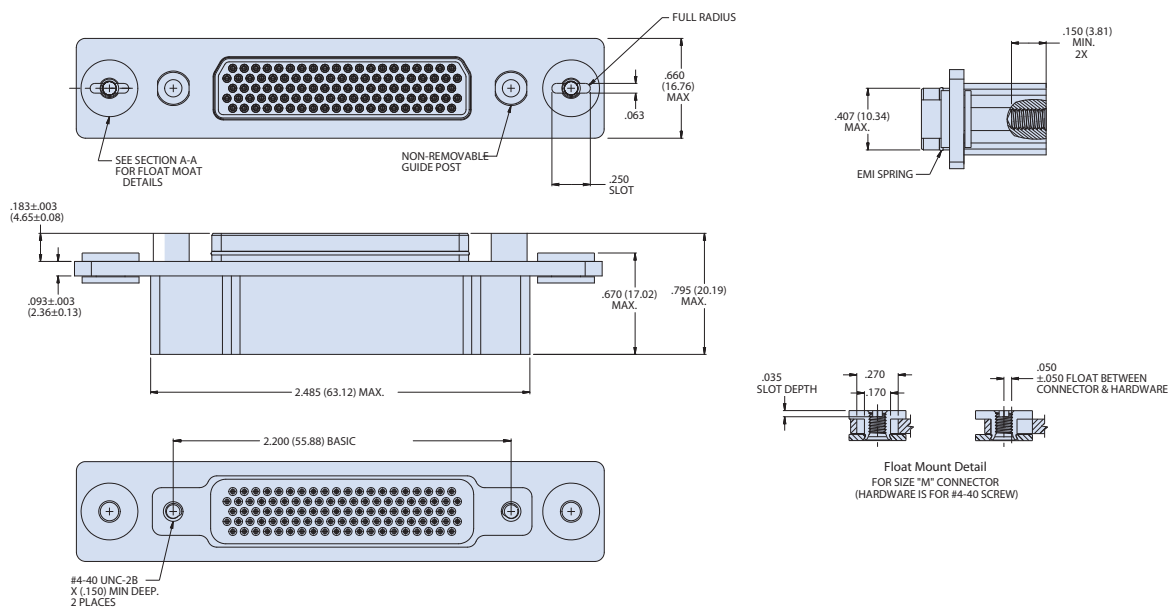

# HIGH-TEMPERATURE TOLERANT ThermaRex HT Series 79 Micro-Crimp High-Performance Crimp-Contact 797-757 Receptacle Details



## CROSS-SECTIONAL VIEW AND HARDWARE

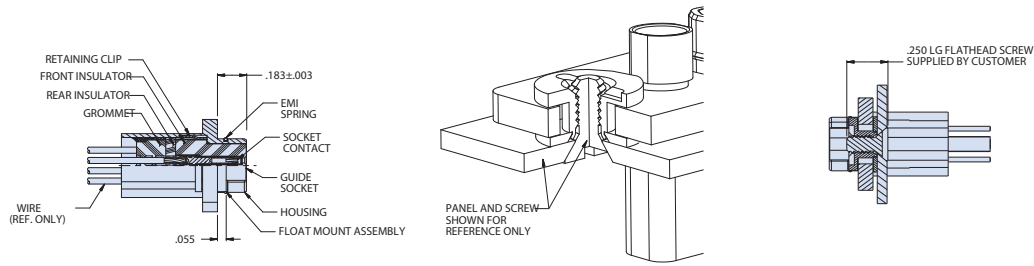

CONNECTOR SUPPLIED WITH NON-REMOVABLE GUIDE POST FOR BLIND MATE APPLICATION.  
FLOAT MOUNT BUSHING HAS SHELL SIZES "M", "L" & "H" WITH #4-40 UNC-2B THREAD. ALL OTHER SIZES HAVE #2-56 UNC-2B THREAD.

## SHELL SIZES A, B, C, D, E, F, J, K

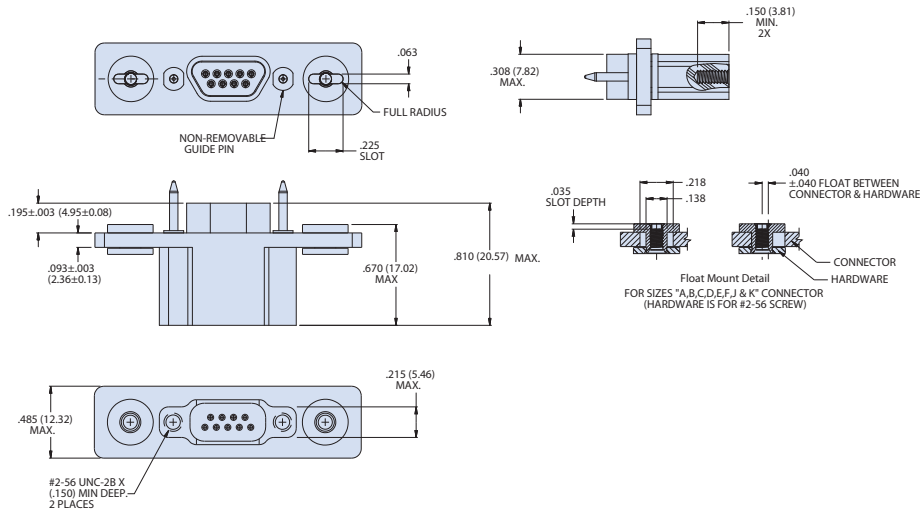

## SHELL SIZE G

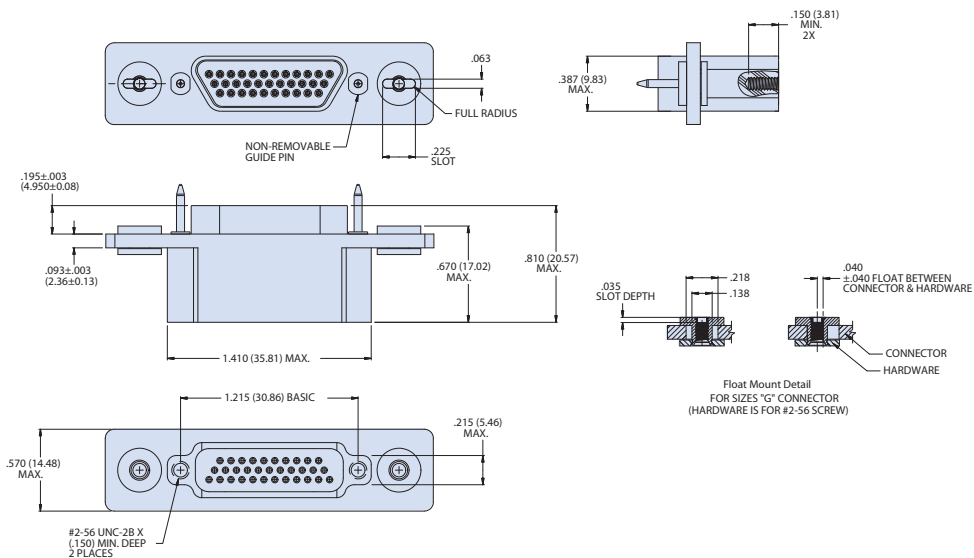

# HIGH-TEMPERATURE TOLERANT ThermaRex HT Series 79 Micro-Crimp High-Performance Crimp-Contact 797-757 Receptacle Details

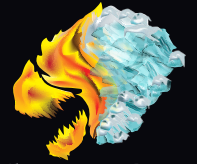

ThermaRex™  
HT

## SHELL SIZES H AND L

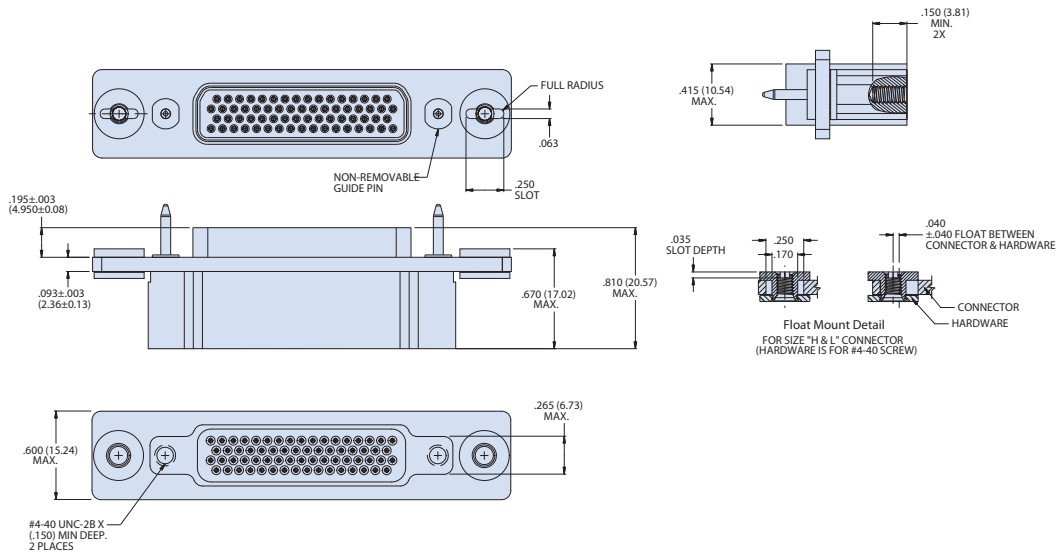

## SHELL SIZE M

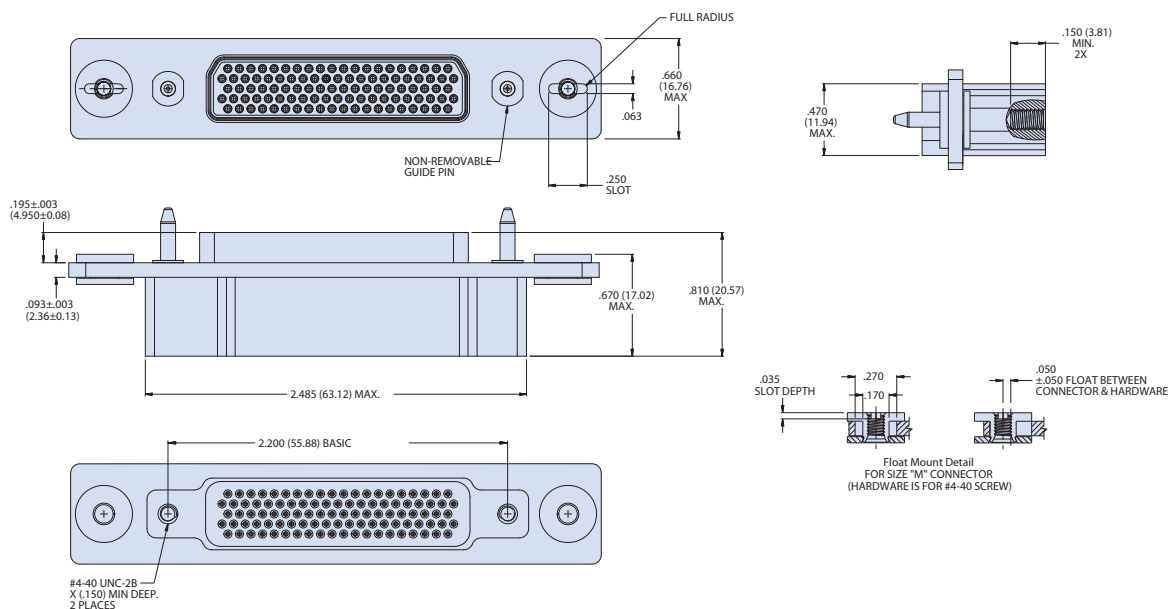

# EXTREME-TEMPERATURE TOLERANT ThermaRex Interconnect Solutions



## 961-047 300°C Ultra-High Temperature Flexible Wire

### 961-047, -65 TO 300°C, STRANDED COPPER WIRE

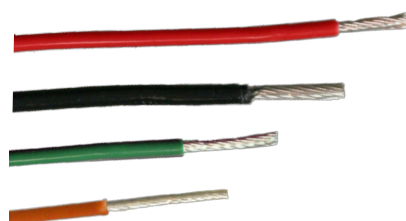

How To Order					
	SAMPLE PART NUMBER	961-047	-N	-A	2
Series / Basic Part No.	961-047 = 300°C ThermaRex Wire				
Material	N = Nickel/Copper (-65°C to 300°C)				
Wire Size	See Table I				
Jacket Color	See Table II				

### NOTES

Bend Radius is 3X the O.D.  
Voltage rating is 1000 volts AC  
Insulation material is 300°C high temperature thermoplastic

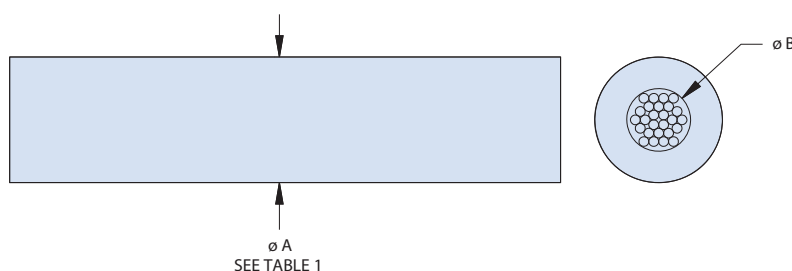

Awg Code	Awg	Strand/Count/Awg	Cir Mil (Nom)	Weight Lbs/1000' (Nom)	Ø A	Ø B	Nickel Copper DC Res @ 20°C ohms/1000ft	Nickel Copper Ampacity (Amps) 40°C Ambient (See Note 2)	Jacket Wall Thickness (In)
A	24	19/36	475	3.45	0.044 (1.12)	0.024 (0.61)	38.4	TBD	0.010 (0.25)
B	22	19/34	754	4.58	0.050 (1.27)	0.030 (0.76)	24.1	TBD	0.010 (0.25)
C	20	19/32	1216	6.43	0.068 (1.73)	0.038 (0.97)	14.8	16	0.015 (0.38)
D	16	37/31	2931	13.1	0.090 (2.29)	0.060 (1.52)	6.33	40	0.015 (0.38)
E	14	7x7/30	4900	21.1	0.121 (3.07)	0.091 (2.31)	3.87	59	0.015 (0.38)
F	12	7x7/29	6257	25.9	0.132 (3.35)	0.102 (2.59)	3.03	78	0.015 (0.38)
G	10	7x19/31	10535	41.5	0.157 (3.99)	0.127 (3.23)	1.81	107	0.015 (0.38)
H	8	7x19/29	16983	63.9	0.191 (4.85)	0.161 (4.09)	1.12	142	0.015 (0.38)
J	6	7x19/27	27200	TBD	0.233 (5.92)	0.203 (5.16)	0.68	TBD	0.015 (0.38)

Color Code	Color
0	Black
1	Brown
2	Red
3	Orange
4	Yellow
5	Kelly Green
6	Blue
7	Violet
8	Gray
9	White

For ambient temperatures other than 40°C (104°F), multiply the allowable ampacities by the appropriate factor shown below.			
Ambient Temp. (°C)	Correction Factors	Ambient Temp. (°C)	Correction Factors
41-50	0.98	161-170	0.71
51-60	0.96	171-180	0.69
61-70	0.94	181-190	0.66
71-80	0.92	191-200	0.63
81-90	0.90	201-210	0.60
91-100	0.88	211-220	0.56
101-110	0.86	221-230	0.53
111-120	0.84	231-240	0.49
121-130	0.81	241-250	0.45
131-140	0.79	251-260	0.40
141-150	0.77	261-270	0.35
151-160	0.74	271-280	0.29



# EXTREME-TEMPERATURE TOLERANT ThermaRex Interconnect Solutions

## 961-087 Ultra-High Temperature Flexible Wire

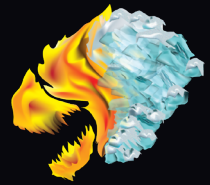

ThermaRex™

### 961-087, -65 TO 450°C, CERAMIC-INSULATED, STRANDED COPPER WIRE

How To Order			
SAMPLE PART NUMBER		961-087	-N -20
Series / Basic Part No.	961-087 UHT Cable, Mica Tape, Ceramic Braid		
Conductor Material	N = Nickel/Copper (-65 to 450 °C)		
Wire Size	See table		

#### NOTES

Braid material shall be Nextel 312, 95% coverage.

Voltage rating is 1000 Volts DC.

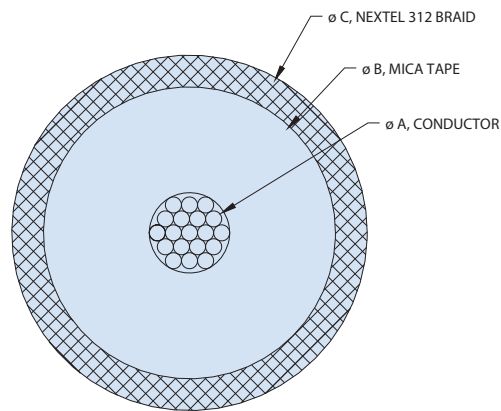

Table I					
AWG	Strand/ Count/AWG	Weight LBS/1000' (NOM)	ø A	ø B	ø C
24	19/36	TBD	0.024 (0.61)	0.104 (2.64)	0.134 (3.40)
22	19/34	TBD	0.030 (0.76)	0.110 (2.79)	0.140 (3.56)
20	19/32	TBD	0.038 (0.97)	0.118 (3.00)	0.148 (3.76)
16	37/31	TBD	0.060 (1.52)	0.140 (3.56)	0.170 (4.32)
14	7x7/30	TBD	0.091 (2.31)	0.171 (4.34)	0.201 (5.11)
12	7x7/29	TBD	0.102 (2.59)	0.182 (4.62)	0.212 (5.38)
10	7x19/31	TBD	0.127 (3.23)	0.207 (5.26)	0.237 (6.02)
8	7x19/29	TBD	0.161 (4.09)	0.241 (6.12)	0.271 (6.88)
6	7x19/27	TBD	0.203 (5.16)	0.283 (7.19)	0.313 (7.95)

# EXTREME-TEMPERATURE TOLERANT ThermaRex Interconnect Solutions



## 961-112 Lightweight, Reduced Diameter Ultra-High Temperature Flexible Wire

### 961-112, -65 TO 450°C, CERAMIC-INSULATED, STRANDED COPPER WIRE

How To Order			
SAMPLE PART NUMBER		961-112	-N -20
Series / Basic Part No.	961-112 UHT Lightweight, Reduced Diameter Wire		
Conductor Material	N = Nickel/Copper (-65 to 450 °C)		
Wire Size	See table		

#### NOTES

Braid material shall be Nextel 312, 95% coverage.

Voltage rating is 1000 Volts DC.

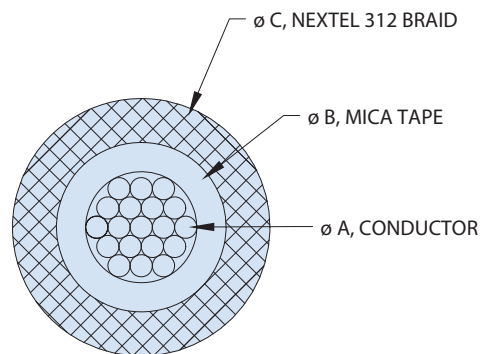
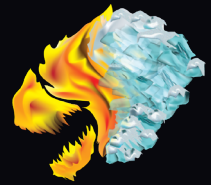

Table I					
AWG	Strand/Count/ AWG	Weight LBS/1000' (NOM)	ø A	ø B	ø C
24	19/36	TBD	0.024 (0.61)	0.044 (1.12)	0.074 (1.88)
22	19/34	TBD	0.030 (0.76)	0.050 (1.27)	0.080 (2.03)
20	19/32	TBD	0.038 (0.97)	0.058 (1.47)	0.088 (2.24)
16	37/31	TBD	0.060 (1.52)	0.080 (2.03)	0.110 (2.79)
14	7x7/30	TBD	0.091 (2.31)	0.111 (2.82)	0.141 (3.58)
12	7x7/29	TBD	0.102 (2.59)	0.122 (3.10)	0.152 (3.86)
10	7x19/31	TBD	0.127 (3.23)	0.147 (3.73)	0.177 (4.50)
8	7x19/29	TBD	0.161 (4.09)	0.181 (4.60)	0.211 (5.36)
6	7x19/27	TBD	0.203 (5.16)	0.223 (5.66)	0.253 (6.43)

# EXTREME-TEMPERATURE TOLERANT ThermaRex Interconnect Solutions

## 961-097 Ultra-High Temperature Flexible Wire



ThermaRex™

### 961-097, -65°C TO 600°C, CERAMIC-INSULATED, STRANDED NICKEL WIRE

How To Order		
SAMPLE PART NUMBER	961-097	-20
Series / Basic Part No.	961-097 UHT Cable, -65°C to 600°C, Ni200 Core, Mica Tape, Ceramic Braid	
Wire Size	See table	

#### NOTES

Braid material shall be Nextel 312, 95% coverage.

Voltage rating is 1000 Volts DC.

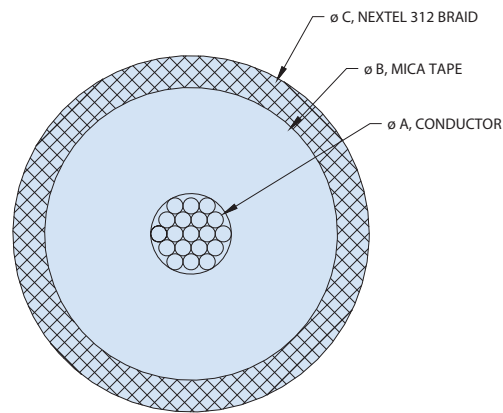

Table I					
AWG	Strand/ Count/AWG	Weight LBS/1000' (NOM)	ø A	ø B	ø C
24	19/36	TBD	0.025 (0.64)	0.105 (2.67)	0.135 (3.43)
22	19/34	TBD	0.032 (0.81)	0.112 (2.84)	0.142 (3.61)
20	7X6/32	TBD	0.041 (1.04)	0.121 (3.07)	0.151 (3.84)
16	7X15/36	TBD	0.065 (1.65)	0.145 (3.68)	0.175 (4.44)

# EXTREME-TEMPERATURE TOLERANT ThermaRex Interconnect Solutions



## 961-137 Lightweight, Reduced Diameter Ultra-High Temperature Flexible Wire

### 961-137, -65°C TO 600°C, CERAMIC-INSULATED, STRANDED NICKEL WIRE

How To Order		
SAMPLE PART NUMBER	961-137	-20
Series / Basic Part No.	961-137 UHT Cable, -65°C to 600°C, Ni200 Core, Mica Tape, Ceramic Braid	
Wire Size	See table	

#### NOTES

Braid material shall be Nextel 312, 95% coverage.

Voltage rating is 1000 Volts DC.

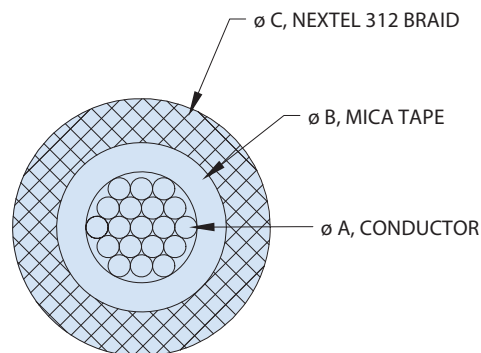

Table I					
AWG	Strand/ Count/AWG	Weight LBS/1000' (NOM)	ø A	ø B	ø C
24	19/36	TBD	0.025 (0.64)	0.041 (1.04)	0.071 (1.80)
22	19/34	TBD	0.032 (0.81)	0.048 (1.22)	0.078 (1.98)
20	7X6/36	TBD	0.041 (1.04)	0.057 (1.45)	0.087 (2.21)
18	7X9/36	TBD	0.050 (1.27)	0.066 (1.68)	0.096 (2.44)
16	7X15/36	TBD	0.065 (1.65)	0.081 (2.06)	0.111 (2.82)



# MISSION-CRITICAL INTERCONNECT SOLUTIONS

## Glenair, Inc.

1211 Air Way • Glendale, California • 91201-2497

Telephone: 818-247-6000 • Fax: 818-500-9912 • sales@glenair.com

[www.glenair.com](http://www.glenair.com)

### Glenair East

20 Sterling Drive  
Wallingford, CT  
06492

Telephone:  
203-741-1115  
Facsimile:  
203-741-0053  
sales@glenair.com

### Glenair UK Ltd

40 Lower Oakham Way  
Oakham Business Park  
Mansfield, Notts  
NG18 5BY England

Telephone:  
+44-1623-638100  
Facsimile:  
+44-1623-638111  
sales@glenair.co.uk

### Glenair Microway Systems

7000 North Lawndale Avenue  
Lincolnwood, IL  
60712

Telephone:  
847-679-8833  
Facsimile:  
847-679-8849

### Glenair Nordic AB

Gustav III : S Boulevard 42  
SE-169 27 Solna  
Sweden

Telephone:  
+46-8-50550000  
sales@glenair.se

### Glenair GmbH

Schaberweg 28  
61348 Bad Homburg  
Germany

Telephone:  
06172 / 68 16 0  
Facsimile:  
06172 / 68 16 90  
info@glenair.de

### Glenair Iberica

C/ La Vega, 16  
45612 Velada  
Spain

Telephone:  
+34-925-89-29-88  
Facsimile:  
+34-925-89-29-87  
sales@glenair.es

### Glenair Italia S.p.A.

Via Del Lavoro, 7  
40057 Quarto Inferiore –  
Granarolo dell'Emilia  
Bologna, Italy

Telephone:  
+39-051-782811  
Facsimile:  
+39-051-782259  
info@glenair.it

### Glenair France SARL

7, Avenue Parmentier  
Immeuble Central Parc #2  
31200 Toulouse  
France

Telephone:  
+33-5-34-40-97-40  
Facsimile:  
+33-5-61-47-86-10  
sales@glenair.fr

### Glenair Korea

6-21Tapsil-ro 58beon-gil  
Giheung-gu, Yongin-si  
Gyeonggi-do  
Republic of Korea

Telephone:  
+82-31-8068-1090  
Facsimile:  
+82-31-8068-1092  
sales@glenair.kr

© 2020 Glenair, Inc.

Printed in U.S.A.