

## ITS 3100 GR and ITS 4100 GR Front Panel Mount Square Flange Receptacle Assembly with Rotating Coupling Nut Backshell for Heat Shrink Tubing

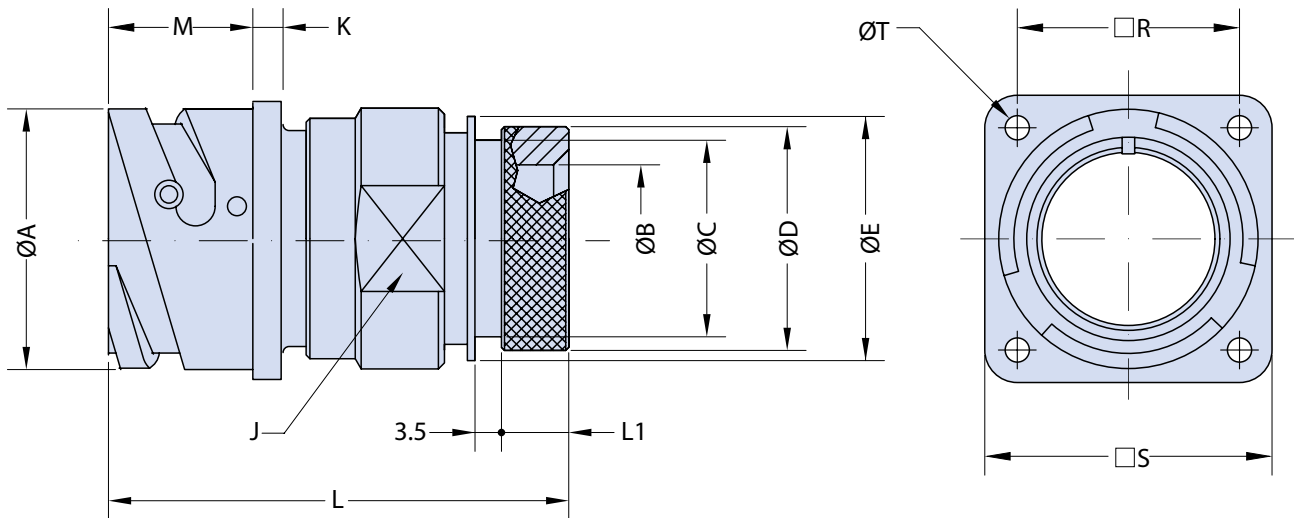
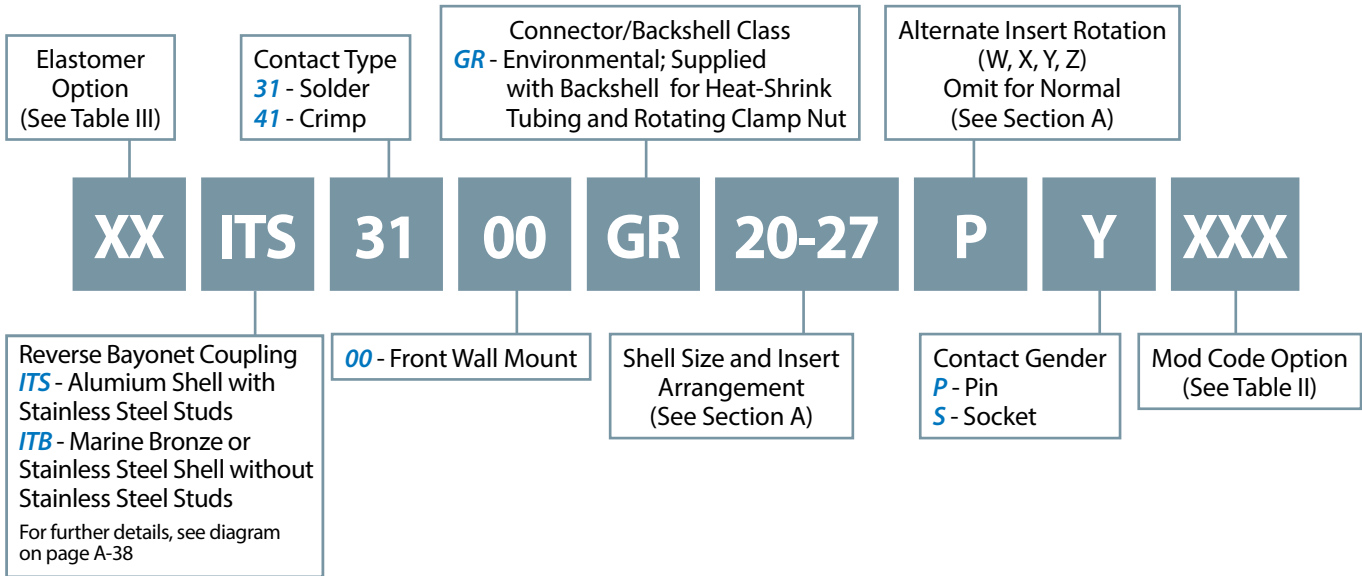

### Application Notes

1. Front mount square flange receptacle assembly with backshell for heat shrink tubing. Rotating coupling nut supplied. Through mounting holes.
2. Connector/Backshell Class "GR" (environmental)—Wire sealing grommet supplied.
3. Standard materials configuration consists of aluminum alloy. For platings, see TABLE II finish options.
4. Standard contact material consists of copper alloy with silver plating or gold plating.

ITS 3100 GR and ITS 4100 GR  
Front Panel Mount Square Flange Receptacle Assembly  
with Rotating Coupling Nut Backshell for Heat Shrink Tubing



TABLE I: DIMENSIONS

Shell Size	ØA +0.2 -0.1	ØB Min.	ØC ±0.1	ØD ±0.2	ØE ±0.1	J Key	K ±0.2	L Max.	L1 ±0.1	M +0.4 0	R ±0.2	S ±0.2	ØT +0.1 0
10 SL	18.2	8.6	13.0	15.5	17.0	20	2.8	55.0	8.2	14.2	18.25	25.4	3.2
14 S	24.5	10.7	16.5	19.1	20.1	23	3.2	55.0	8.2	14.2	23.00	30.4	3.2
16 S	27.2	14.0	24.9	23.9	23.5	26	3.2	55.0	8.0	14.2	24.60	32.5	3.2
16	27.2	14.0	24.9	23.9	23.5	26	3.2	61.0	8.0	19.0	24.60	32.5	3.2
18	30.7	17.5	21.7	23.9	26.5	28	4.0	64.5	8.0	19.0	27.00	35.0	3.2
20	34.0	18.8	26.2	29.6	30.2	32	4.0	64.5	8.9	19.0	29.40	38.0	3.2
22	37.3	21.0	26.2	29.6	33.6	36	4.0	64.5	9.2	19.0	31.75	41.0	3.2
24	40.9	25.4	34.0	37.8	36.1	39	4.0	68.5	9.5	20.6	34.90	44.5	3.7
28	46.7	28.4	34.3	37.8	41.4	46	4.0	68.5	9.2	20.6	39.70	50.9	3.7
32	53.4	34.0	43.6	47.8	48.6	52	4.0	70.0	11.7	22.2	44.50	57.0	4.3
36	59.6	40.5	43.6	47.8	54.0	58	4.0	70.0	11.5	22.2	49.20	63.5	4.3
40	65.5	49.0	52.6	57.8	61.0	65	4.0	70.0	11.5	22.2	55.55	69.9	4.3

TABLE II: MODIFICATION CODES

CONTACT OPTIONS		
Sym	Description	
B0	Connector without Contacts**	
B1	Connector with Gold Plated Contacts	
<b>Omit for standard version (Silver plated)</b>		
STANDARD MATERIAL AND FINISH (*)		
Sym	Description	RoHS
	Omit for Aluminum/ Cadmium Olive Drab	
F6	Aluminum/ Black Electrodeposited Paint	✓
F7	Aluminum/ Black Zinc Nickel	✓
F11	Aluminum/ Electroless Nickel	✓
MB	Marine Bronze/ Unplated	✓
FK	Stainless Steel/ Passivate	✓

TABLE III

ELASTOMER OPTIONS	
Sym	Description
	Omit for Polychloroprene Elastomer
FR	Fire Resistant Elastomer
S	Silicone Elastomer

(\*) For further options, please contact the factory.

(\*\*) Crimp Contacts Only