

HIGH-TEMPERATURE TOLERANT ThermaRex HT SuperNine[®] Connectors



High-performance fast mate/demate solution



- Service rating up to 300°C
- Vibration-resistant threaded coupling
- High-temperature ceramic insulators and silicone seals
- Durable stainless steel construction

How To Order ThermaRex SuperNine connectors							
Sample Part Number	233-273	-20	Z1	17	-26	P	N
Series / Basic Part No.	233-273 High-temperature ThermaRex SuperNine connector						
Connector Style	-20 = Receptacle, square flange-mount -24 = Receptacle, jam nut -26 = Plug						
Material/Finish	Z1 = Passivated CRES						
Shell Size	9, 11, 13, 17, 19, 21, 23, 25						
Insert Arrangement	Per M1560. See insert arrangement tables below						
Contact Style	P = Pin contacts S = Socket contacts A = Pin insert, less contacts B = Socket insert, less contacts						
Alternate Polarization*	A, B, C, D, E, N = Normal (IAW MIL-DTL-38999 Series III)						

MATERIAL / FINISH NOTES

Plug and receptacle shells, coupling nut - Passivated CRES
 Insulator - high-grade ceramic dielectric
 Grommet, interfacial, and peripheral seals - high-temp silicone
 Contacts - copper alloy, gold plated, CRES hood and crown ring on socket contacts

ThermaRex High-Temperature Crown Ring Contact Arrangements (pin mating face shown)				
Suggested high-availability contact arrangements show. Most MIL-STD-1560 arrangements are available, consult factory.				
9-35 Contact Size : 22D Qty.: 6 Service Rating: M	11-99 Contact Size : 20 Qty.: 7 Service Rating: I	11-35 Contact Size : 22D Qty.: 13 Service Rating: M	13-8 Contact Size : 20 Qty.: 8 Service Rating: I	13-35 Contact Size : 22D Qty.: 22 Service Rating: M
15-97 Contact Size : 20 / Quantity: 8 Contact Size : 16 / Quantity: 4 Service Rating: I	17-6 Contact Size : 12 Qty.: 6 Service Rating: I	21-24 Contact Size : 20 Qty.: 24 Service Rating: I		

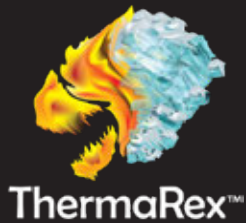

HIGH-TEMPERATURE TOLERANT

ThermaRex HT SuperNine® Connectors



High-performance fast mate/demate solution

233-273-24 THERMAREX SUPERNINE RECEPTACLE, JAM NUT

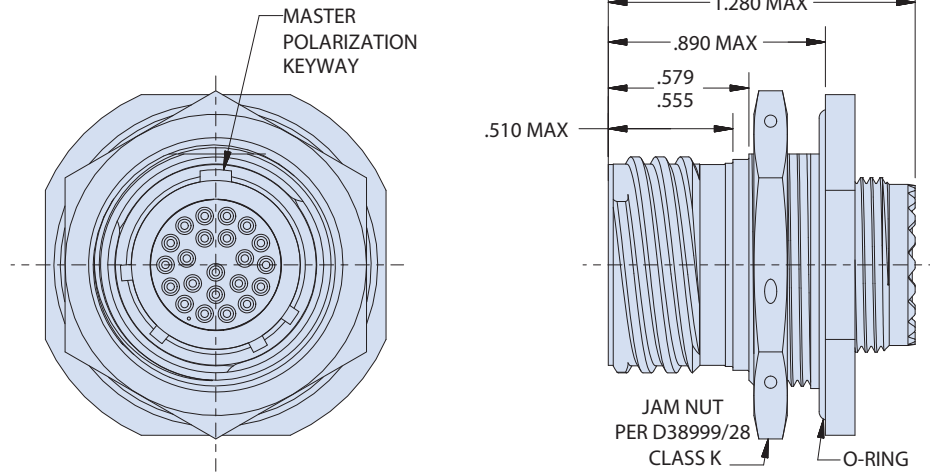

233-273-26 THERMAREX SUPERNINE PLUG

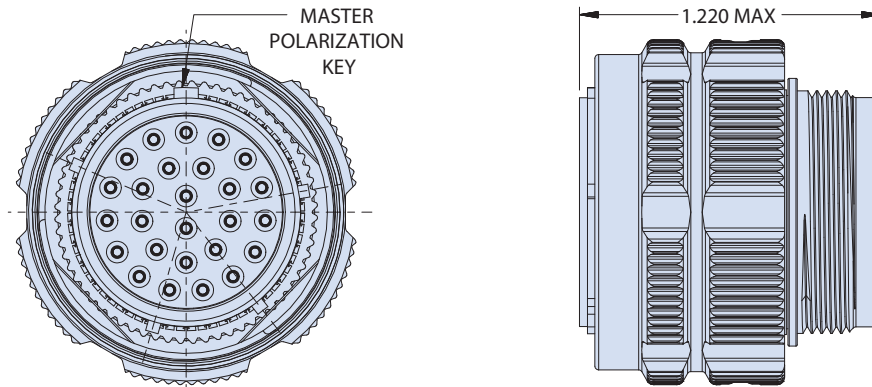

233-273-20 THERMAREX SUPERNINE RECEPTACLE, SQUARE FLANGE-MOUNT

